

SD系列 精密双向滚珠丝杠标准库存品

SD series Standardized Bi-directional Ball Screws

通过单轴即可进行左右开闭、定心、精密定位的经济型滚珠丝杠。
齐备有C3级、C5级研磨滚珠丝杠。

SD series are economical Ball Screws which moves bi-directionally with a shaft, and perform centering, precise positioning. There are Precision Ball Screws C3, C5 grade.

●丝杠轴公称外径与导程的组合

Combination of Shaft nominal dia. & Lead

Unit(单位):mm

Shaft dia. 公称外径	Lead 导程	1	2
4		A239	
6		A240	
8		A241	A242
10			A243
12			A244

注1)表中的数字表示产品刊载页码。

Note 1)The numbers in a table: showing a page in this catalogue.

●精度等级和轴向间隙

SD系列(精密双向滚珠丝杠标准库存品)的精度等级有C3和C5(JIS B 1192-3)两种。
轴向间隙根据精度等级不同备有0mm(预压:C3)和0.005mm以下(C5)两种。

●Accuracy Grade & Axial play

Accuracy grades of SD series(Standardized Bidirectional Precision Ball Screws) are 2 kinds, C3 and C5(JIS B 1192-3). Axial play are 0(Preload : C3)and 0.005mm or less(C5) corresponding to accuracy grades in stock.

●材质和表面硬度

SD系列(精密双向滚珠丝杠标准库存品)的丝杠轴和螺母均采用SCM415(渗碳淬火),滚珠丝杠部分的表面硬度为HRC58~62。

●Material & Surface hardness

Shafts and Nuts of SD series(Standardized Bi-directional Precision Ball Screws) adopts SCM415 (carburizing and quenching), surface hardness of Ball Screw part is HRC58-62.

●润滑

为防止生锈,未对轴端进行加工的SD系列(精密双向滚珠丝杠标准库存品)产品均涂抹有防锈油。由于防锈油不具备润滑性,因此在使用前请另行涂抹润滑剂。
如无特殊指定,建议使用KSS原装润滑油脂(MSG No.2)。

●Lubrication

SD series(Standardized Bi-directional Precision Ball Screws) are applied with anti-rust oil for rust prevention when unfinished end journal. Since anti-rust oil is not lubricant, apply Grease or lubrication oil before using Ball Screws.
If there is no specific instruction, KSS would recommend our original Grease (MSG No.2) as standard lubricant.
Please feel free to contact us.

●轴端形状

SD系列(精密双向滚珠丝杠标准库存品)的轴端形状未进行标准化。
委托KSS进行追加加工时,请附上指示轴端形状的图纸。

●End-journal profile

End-journal configuration of SD series (Standardized Bi-directional Precision Ball Screws) is not standardized. Please ask for KSS regarding additional machining with a drawing which shows end-journal profile.

●公称型号的构成

SD系列(精密双向滚珠丝杠标准库存品)的公称型号构成如下所示。

●Model number notation

Model number notation of SD series(Standardized Bi-directional Precision Ball Screws) is as follows.

SD **08** **01** — **120** **L** **120** **R** **300** **C5**

① ② ③ ④ ⑤ ⑥ ⑦ ⑧ ⑨

- ①双向滚珠丝杠的系列符号
- ②丝杠轴公称外径(mm)
- ③导程(mm)
- ④左旋螺纹部长度(mm)
- ⑤左旋符号
- ⑥右旋螺纹部长度(mm)
- ⑦右旋符号
- ⑧丝杠轴总长(mm)
- ⑨精度等级(C3或C5)

- ①Bi-directional Ball Screws series No.
- ②Screw Shaft nominal diameter(mm)
- ③Lead(mm)
- ④Left-side thread length(mm)
- ⑤Left-hand
- ⑥Right-side thread length(mm)
- ⑦Right-hand
- ⑧Screw Shaft total length(mm)
- ⑨Accuracy grade(C3 or C5)

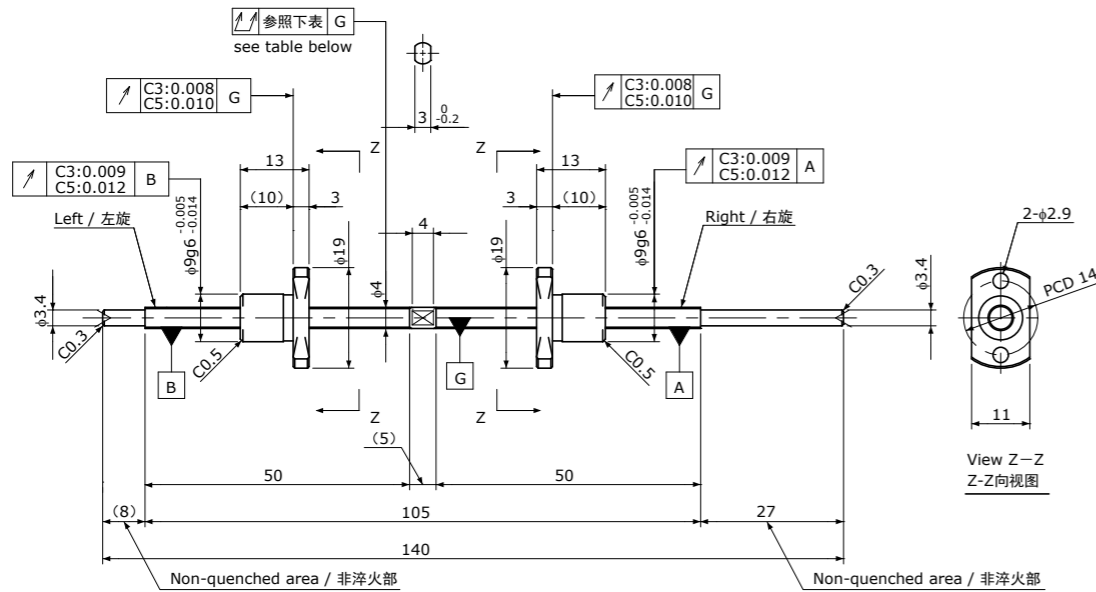
Standard products in stock SD series
标准库存品 SD系列SD0401 | Shaft dia.(轴径) $\phi 4$ Lead(导程)1mm | C3&C5

Unit(单位):mm

Ball Screw Specifications 主要技术参数	
Ball size 钢珠直径	$\phi 0.6$
Number of thread 螺纹条数	1
Thread direction 螺纹旋向	Left&Right 左右
Shaft root dia. 丝杠轴底径	$\phi 3.4$
Number of circuit 循环数	1×3
Shaft,Nut material 轴、螺母材质	SCM415H
Surface hardness 螺纹部表面硬度	HRC58~62 (Thread area)
Anti-rust treatment 防锈处理	Anti-rust oil 防锈油

Unit(单位):mm

Ball Screw Model 滚珠丝杠型号	Travel 行程	Grade 精度	Lead accuracy 导程精度		Total Run-out 全跳动	Axial play 轴向间隙	Preload Torque 预压扭矩 Nm	Basic Load Rating 基本额定负载 N	
			Travel deviation 代表移动量误差 e_p	Variation 波动 V_u				Dynamic 额定动负载 C_a	Static 额定静负载 C_{oa}
SD0401-50L50R140C3	35	C3	± 0.008	0.008	0.035	0	~ 0.010	300	430
SD0401-50L50R140C5	35	C5	± 0.018	0.018	0.050	~ 0.005	—		

Note 1) Please designate end-journal profile with your sketch.

Note 2) Absolute position of both Nuts related to the Screw Shaft is not under the control.

注1)轴端的追加加工请结合图纸进行指示。

注2)未规定左右螺母相对于丝杠轴的绝对位置。

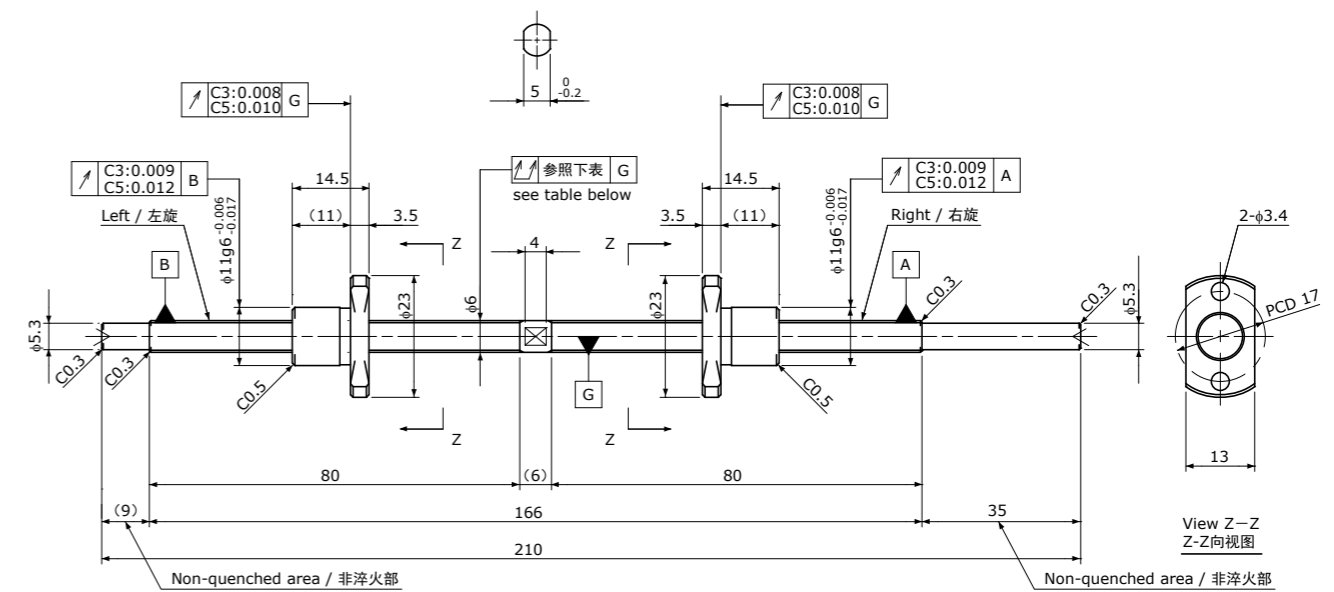
Standard products in stock SD series
标准库存品 SD系列SD0601 | Shaft dia.(轴径) $\phi 6$ Lead(导程)1mm | C3&C5

Unit(单位):mm

Ball Screw Specifications 主要技术参数	
Ball size 钢珠直径	$\phi 0.8$
Number of thread 螺纹条数	1
Thread direction 螺纹旋向	Left&Right 左右
Shaft root dia. 丝杠轴底径	$\phi 5.3$
Number of circuit 循环数	1×3
Shaft,Nut material 轴、螺母材质	SCM415H
Surface hardness 螺纹部表面硬度	HRC58~62 (Thread area)
Anti-rust treatment 防锈处理	Anti-rust oil 防锈油

Unit(单位):mm

Ball Screw Model 滚珠丝杠型号	Travel 行程	Grade 精度	Lead accuracy 导程精度		Total Run-out 全跳动	Axial play 轴向间隙	Preload Torque 预压扭矩 Nm	Basic Load Rating 基本额定负载 N	
			Travel deviation 代表移动量误差 e_p	Variation 波动 V_u				Dynamic 额定动负载 C_a	Static 额定静负载 C_{oa}
SD0601-80L80R210C3	65	C3	± 0.008	0.008	0.050	0	~ 0.013	550	1000
SD0601-80L80R210C5	65	C5	± 0.018	0.018	0.065	~ 0.005	—		

Note 1) Please designate end-journal profile with your sketch.

Note 2) Absolute position of both Nuts related to the Screw Shaft is not under the control.

注1)轴端的追加加工请结合图纸进行指示。

注2)未规定左右螺母相对于丝杠轴的绝对位置。

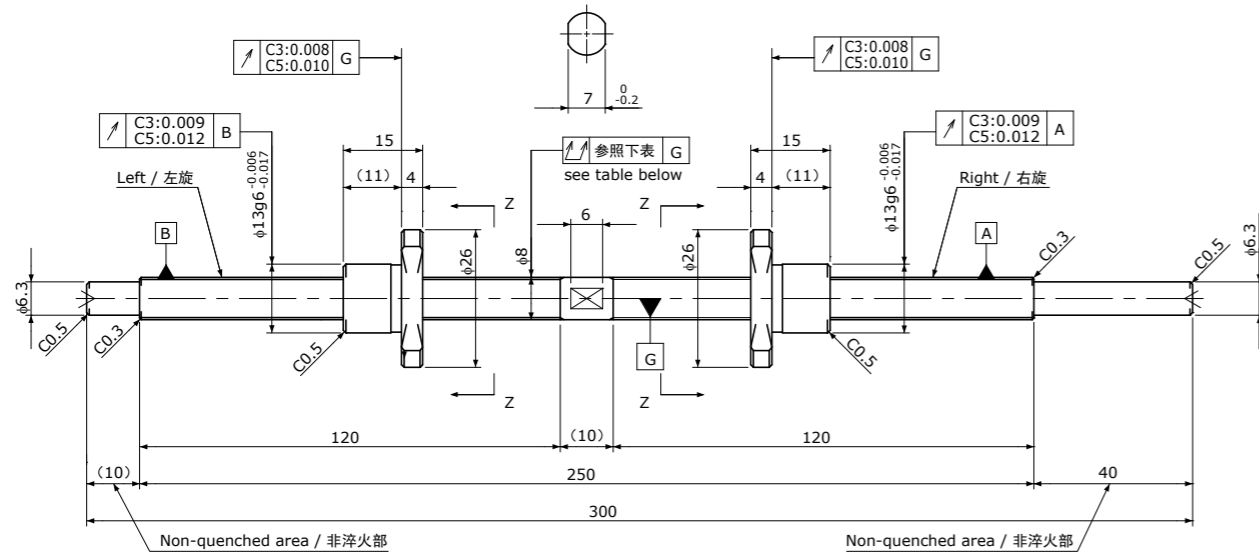
Standard products in stock SD series
标准库存品 SD系列SD0801 | Shaft dia.(轴径) $\phi 8$ Lead(导程)1mm | C3&C5

Unit(单位):mm

Ball Screw Specifications 主要技术参数	
Ball size 钢珠直径	$\phi 0.8$
Number of thread 螺纹条数	1
Thread direction 螺纹旋向	Left&Right 左右
Shaft root dia. 丝杠轴底径	$\phi 7.3$
Number of circuit 循环数	1×3
Shaft,Nut material 轴、螺母材质	SCM415H
Surface hardness 螺纹部表面硬度	HRC58~62 (Thread area)
Anti-rust treatment 防锈处理	Anti-rust oil 防锈油

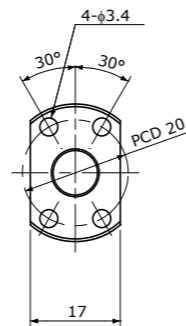
View Z-Z
Z-Z向视图

Unit(单位):mm

Ball Screw Model 滚珠丝杠型号	Travel 行程	Grade 精度	Lead accuracy 导程精度		Total Run-out 全跳动	Axial play 轴向间隙	Preload Torque 预压扭矩 Nm	Basic Load Rating 基本额定负载 N	
			Travel deviation 代表移动量误差 e_p	Variation 波动 V_u				Dynamic 额定动负载 C_a	Static 额定静负载 C_{0a}
SD0801-120L120R300C3	105	C3	± 0.010	0.008	0.050	0	~0.018	650	1300
SD0801-120L120R300C5	105	C5	± 0.020	0.018	0.065	~0.005	—		

Note 1) Please designate end-journal profile with your sketch.
Note 2) Absolute position of both Nuts related to the Screw Shaft is not under the control.

注1)轴端的追加加工请结合图纸进行指示。
注2)未规定左右螺母相对于丝杠轴的绝对位置。

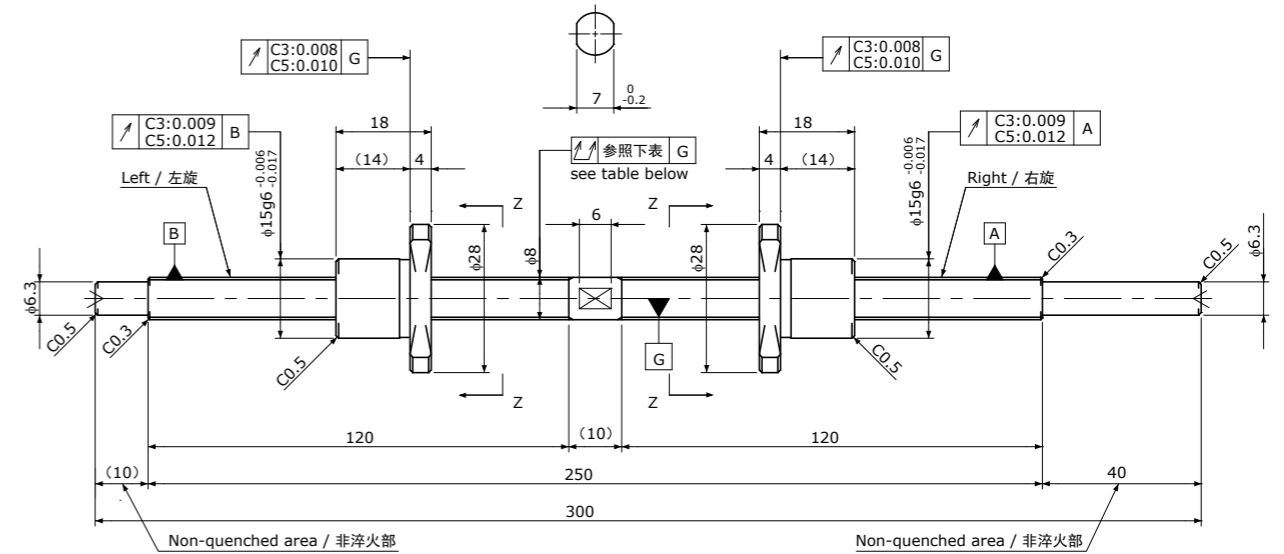
Standard products in stock SD series
标准库存品 SD系列SD0802 | Shaft dia.(轴径) $\phi 8$ Lead(导程)2mm | C3&C5

Unit(单位):mm

Ball Screw Specifications 主要技术参数	
Ball size 钢珠直径	$\phi 1.2$
Number of thread 螺纹条数	1
Thread direction 螺纹旋向	Left&Right 左右
Shaft root dia. 丝杠轴底径	$\phi 7.0$
Number of circuit 循环数	1×3
Shaft,Nut material 轴、螺母材质	SCM415H
Surface hardness 螺纹部表面硬度	HRC58~62 (Thread area)
Anti-rust treatment 防锈处理	Anti-rust oil 防锈油

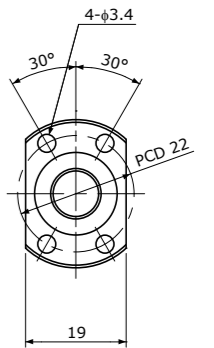
View Z-Z
Z-Z向视图

Unit(单位):mm

Ball Screw Model 滚珠丝杠型号	Travel 行程	Grade 精度	Lead accuracy 导程精度		Total Run-out 全跳动	Axial play 轴向间隙	Preload Torque 预压扭矩 Nm	Basic Load Rating 基本额定负载 N	
			Travel deviation 代表移动量误差 e_p	Variation 波动 V_u				Dynamic 额定动负载 C_a	Static 额定静负载 C_{0a}
SD0802-120L120R300C3	100	C3	± 0.010	0.008	0.050	0	~0.020	1300	2300
SD0802-120L120R300C5	100	C5	± 0.020	0.018	0.065	~0.005	—		

Note 1) Please designate end-journal profile with your sketch.
Note 2) Absolute position of both Nuts related to the Screw Shaft is not under the control.

注1)轴端的追加加工请结合图纸进行指示。
注2)未规定左右螺母相对于丝杠轴的绝对位置。

Standard products in stock SD series
标准库存品 SD系列

SD1002 | Shaft dia.(轴径) $\phi 10$ Lead(导程)2mm | C3&C5

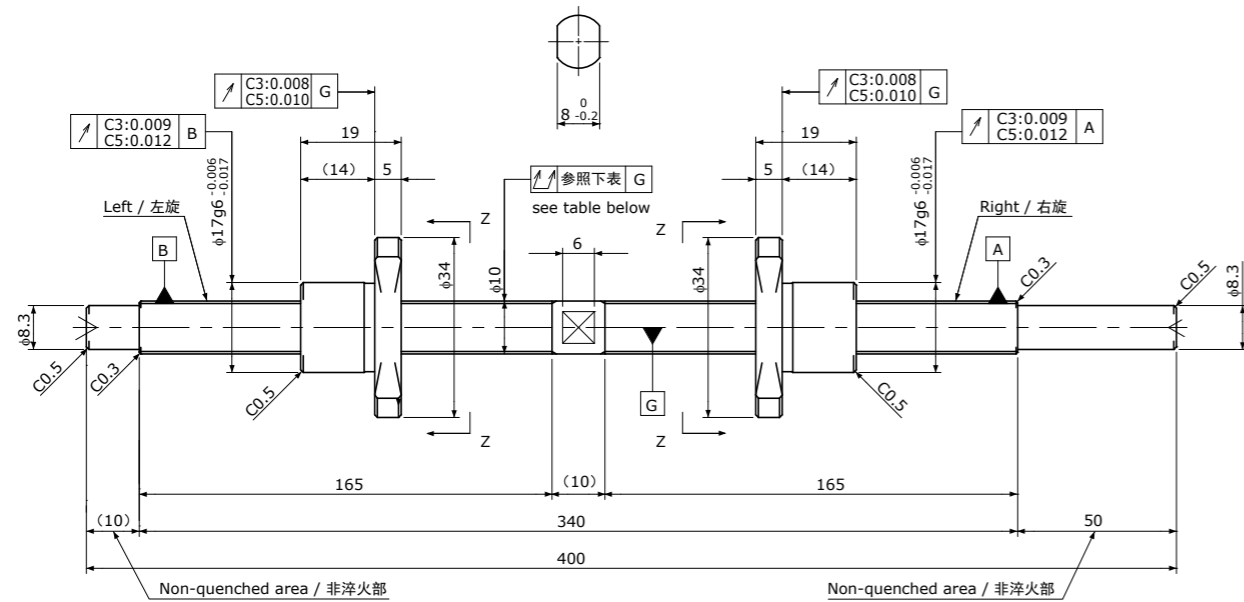

Unit(单位):mm

Ball Screw Specifications 主要技术参数	
Ball size 钢珠直径	$\phi 1.2$
Number of thread 螺纹条数	1
Thread direction 螺纹旋向	Left&Right 左右
Shaft root dia. 丝杠轴底径	$\phi 9.0$
Number of circuit 循环数	1×3
Shaft,Nut material 轴、螺母材质	SCM415H
Surface hardness 螺纹部表面硬度	HRC58~62 (Thread area)
Anti-rust treatment 防锈处理	Anti-rust oil 防锈油

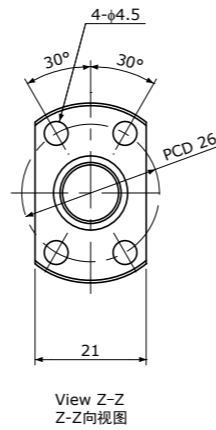

Unit(单位):mm

Ball Screw Model 滚珠丝杠型号	Travel 行程	Grade 精度	Lead accuracy 导程精度		Total Run-out 全跳动	Axial play 轴向间隙	Preload Torque 预压扭矩 Nm	Basic Load Rating 基本额定负载 N	
			Travel deviation 代表移动量误差 e_p	Variation 波动 V_u				Dynamic 额定动负载 C_a	Static 额定静负载 C_{oa}
SD1002-165L165R400C3	145	C3	± 0.010	0.008	0.050	0	~0.025	1450	3000
SD1002-165L165R400C5	145	C5	± 0.020	0.018	0.065	~0.005	—		

Note 1) Please designate end-journal profile with your sketch. 注1)轴端的追加加工请结合图纸进行指示。
Note 2) Absolute position of both Nuts related to the Screw Shaft is not under the control. 注2)未规定左右螺母相对于丝杠轴的绝对位置。

Standard products in stock SD series
标准库存品 SD系列

SD1202 | Shaft dia.(轴径) $\phi 12$ Lead(导程)2mm | C3&C5

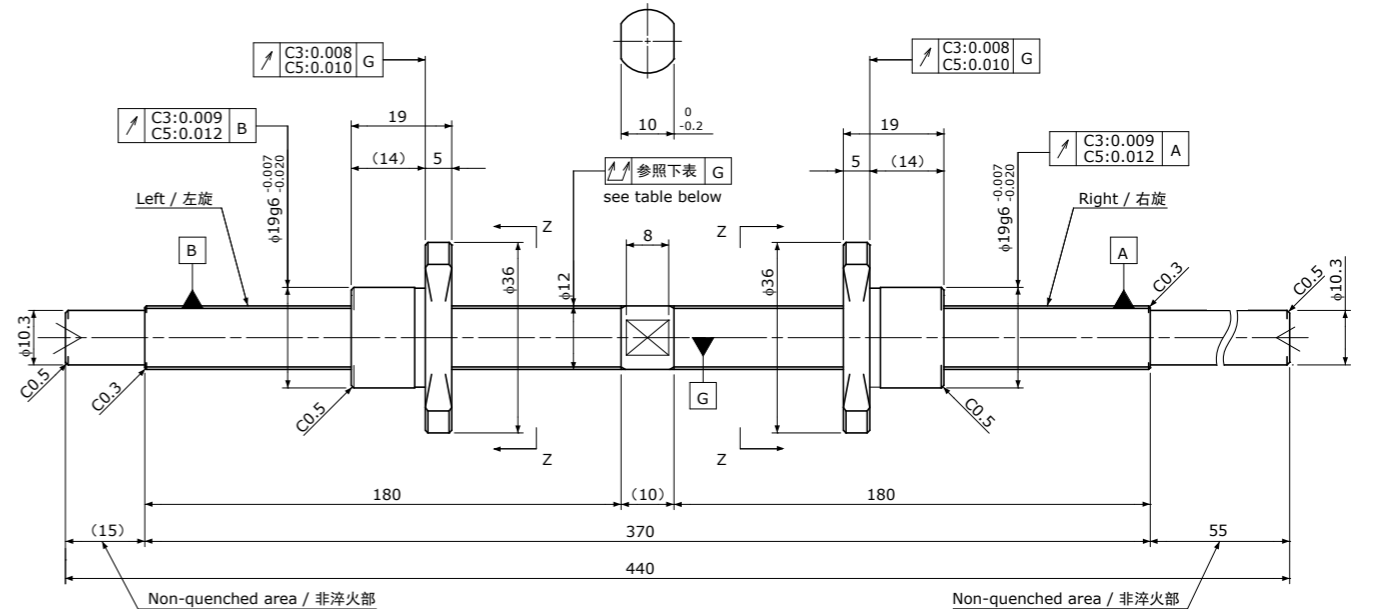

Unit(单位):mm

Ball Screw Specifications 主要技术参数	
Ball size 钢珠直径	$\phi 1.2$
Number of thread 螺纹条数	1
Thread direction 螺纹旋向	Left&Right 左右
Shaft root dia. 丝杠轴底径	$\phi 11.0$
Number of circuit 循环数	1×3
Shaft,Nut material 轴、螺母材质	SCM415H
Surface hardness 螺纹部表面硬度	HRC58~62 (Thread area)
Anti-rust treatment 防锈处理	Anti-rust oil 防锈油

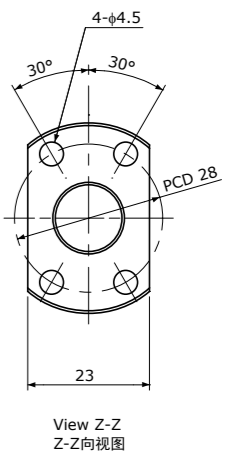

Unit(单位):mm

Ball Screw Model 滚珠丝杠型号	Travel 行程	Grade 精度	Lead accuracy 导程精度		Total Run-out 全跳动	Axial play 轴向间隙	Preload Torque 预压扭矩 Nm	Basic Load Rating 基本额定负载 N	
			Travel deviation 代表移动量误差 e_p	Variation 波动 V_u				Dynamic 额定动负载 C_a	Static 额定静负载 C_{oa}
SD1202-180L180R440C3	160	C3	± 0.010	0.008	0.065	0	~0.035	1600	3700
SD1202-180L180R440C5	160	C5	± 0.020	0.018	0.080	~0.005	—		

Note 1) Please designate end-journal profile with your sketch. 注1)轴端的追加加工请结合图纸进行指示。
Note 2) Absolute position of both Nuts related to the Screw Shaft is not under the control. 注2)未规定左右螺母相对于丝杠轴的绝对位置。