

SG系列 精密滚珠丝杠标准库存品

SG series Standardized Precision Ball Screws

齐备有C3级、C5级精密滚珠丝杠，固定侧轴端事先经过标准化加工。

只要对支撑侧轴端进行加工，便可按所需形状在短期内供货。

Precision Ball Screws which are accuracy C3, C5 and have machined shaft end at fixed side in advance are available. Short delivery is available by machining supported end in accordance with customer's request.

●丝杠轴公称外径与导程的组合 Combination of Shaft nominal dia. & Lead

Unit(单位):mm

Lead 导程	0.5	1	2	2.5	4	5	6	8	10	12	15	20
3	A207	A208										
4		A209	A210									
5					A211							
6		A212	A213	A214			A215		A216			
8		A217	A218	A219	A220	A221		A222		A223		
10		A224	A225		A226	A227			A228		A229	
12			A230						A231			
14			A232		A233							
15						A234			A235			A236

注1) 表中的数字表示产品刊载页码。

Note 1) The number in a table : showing a page in this catalogue.

●精度等级和轴向间隙

SG系列（精密滚珠丝杠标准库存品）的精度等级有C3和C5（JIS B 1192-3）两种。轴向间隙根据精度等级不同备有0mm（预压：C3）和0.005mm以下（C5）两种。

●材质和表面硬度

SG系列（精密滚珠丝杠标准库存品）的丝杠轴和螺母均采用SCM415（渗碳淬火），滚珠丝杠部分的表面硬度为HRC58~62。

●润滑

为防止生锈，未对轴端进行加工的SG系列（精密滚珠丝杠标准库存品）产品均涂抹有防锈油。由于防锈油不具备润滑性，因此在使用前请另行涂抹润滑剂。如无特殊指定，建议使用KSS原装润滑油脂（MSG No.2）。

●接单生产

上述标准品以外的产品均为接单生产。详情请垂询本公司。

●Accuracy Grade & Axial play

Accuracy grade of SG series (Standardized Precision Ball Screws) are based on C3 and C5 (JIS B 1192-3). According to accuracy grade, Axial play 0 (Preload : C3) and 0.005mm or less (C5) are in stock.

●Material & Surface hardness

SG series (Standardized Precision Ball Screws) consists of Shaft and Nut materials SCM415 (Carburizing and quenching) and Surface hardness is HRC58~62.

●Lubrication

SG series (Standardized Precision Ball Screws) without end-journal machining will be applied with anti-rust oil for rust prevention. Anti-rust oil does not have lubricating function so that please apply Grease or lubrication oil when using the Ball Screws.

If there is no specific instruction, KSS would recommend our original Grease (MSG No.2) as standard lubricant.

Please feel free to contact us.

●Customized products

It will be a customized product other than the above. Please ask KSS.

●公称型号的构成

希望对SG系列进行追加加工时，请用以下公称型号进行指示。

SG 04 01 — 046 R 085 C3 B 1 X

① ② ③ — ④ ⑤ ⑥ ⑦ ⑧ ⑨ ⑩

- ①系列符号
- ②丝杠轴公称外径(mm)
- ③导程(mm)
- ④螺纹部长度(mm)
(追加加工后以1mm为单位指定)
- ⑤螺纹旋向(R=右旋)
- ⑥丝杠轴总长(mm)
(以1mm为单位指定)
- ⑦精度等级(C3或C5)
- ⑧支撑侧轴端加工型
(参照图A-22: A型、B型、C型、D型(其他))
- ⑨涂抹的油脂
0: 本公司推荐的润滑脂(MSG No.2)
1: 防锈油(Non Ruster PZ2)
2: Multemp PS2
3: 其他
- ⑩螺母法兰朝向(参照图A-23)

●Model number notation

Please use model number below when additional end-journal machining is requested.

- ①Ball Screws Series No.
- ②Screw Shaft nominal diameter(mm)
- ③Lead(mm)
- ④Screw thread length(mm)
(Specify in 1mm units after end-journal machining)
- ⑤Thread direction(R=Right-hand)
- ⑥Screw Shaft total length(mm)
(Specify in 1mm units)
- ⑦Accuracy grade(C3 or C5)
- ⑧Shaft supported end profile
Refer to Fig. A-22 below : A-type,B-type,C-type,D-type(other)
- ⑨Anti-rust oil or Lubricant
0 : KSS grease (MSG No.2)
1 : Anti-rust oil(Non Ruster PZ2)
2 : Multemp PS2 grease
3 : Other
- ⑩Nut Flange direction (Refer to Fig. A-23 below)

图A-22 : 支撑侧轴端加工型
Fig. A-22 : Shaft supported end profile

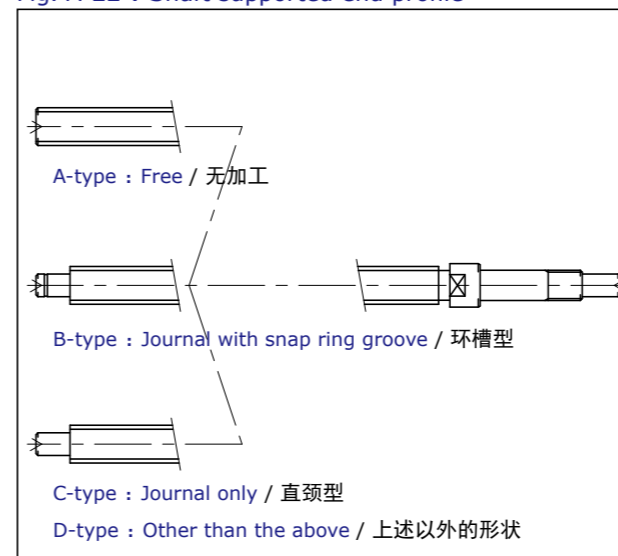

●注释

- 1) 各种规格的轴端形状在各项中有详细介绍。
- 2) 不受理螺母的追加加工。
- 3) 本规格若有变更，恕不另行通告。
- 4) 希望进行A、B、C以外的轴端加工时，请垂询本公司。

图A-23 : 螺母法兰朝向
Fig. A-23 : Nut Flange direction

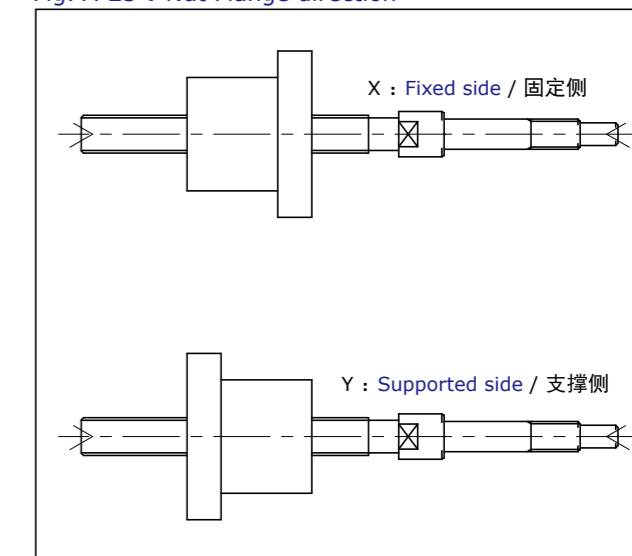

●Note

- 1) The detail of end-journal dimension for each size is shown from next page.
- 2) KSS does not make additional Nut machining.
- 3) The specification is subject to change without notice.
- 4) If the other configuration except (A,B,C) is requested, please contact KSS.

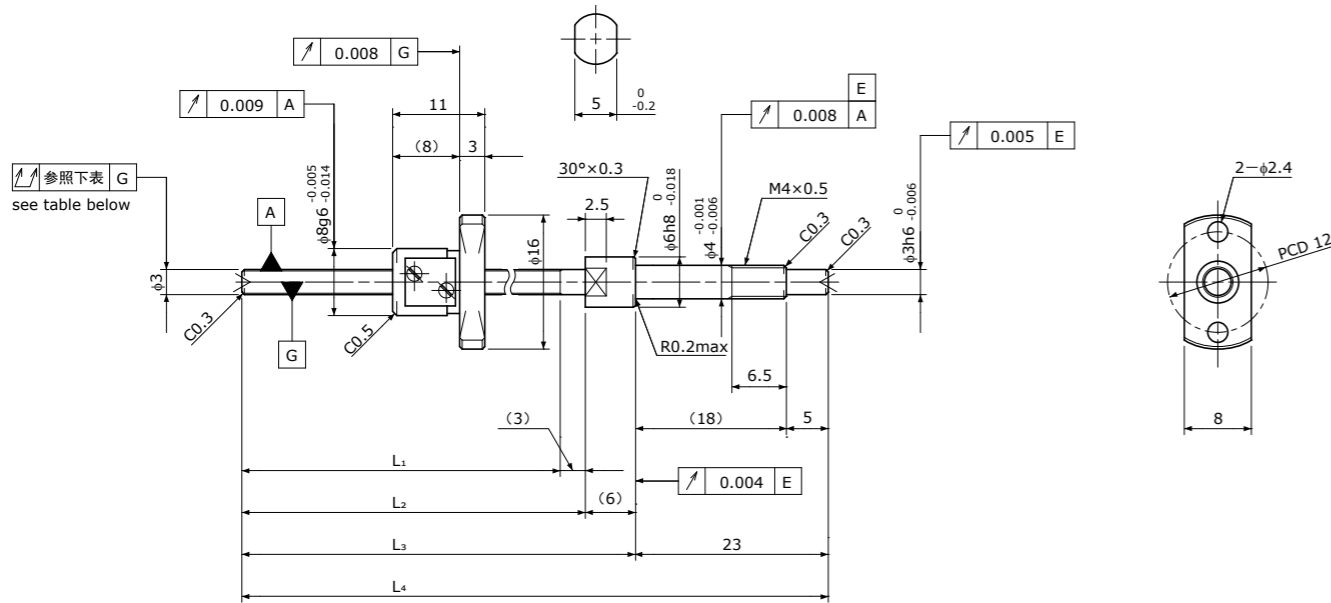
Standard products in stock SG series
标准库存品 SG系列SG0300.5 | Shaft dia.(轴径) $\phi 3$ Lead(导程)0.5mm | C3

Unit(单位):mm

Ball Screw Specifications 主要技术参数		Supported-side end-journal profile 支撑侧轴端加工形状							
Ball size 钢珠直径	$\phi 0.4$	A-type							
Number of thread 螺纹条数	1								
Thread direction 螺纹旋向	Right 右旋	$L_5 = L_6 - 32$ L_6							
Shaft root dia. 丝杠轴底径	$\phi 2.6$	L ₅ : Thread length after end-journal machining. 追加加工后的螺纹部长度 L ₆ : Total length after end-journal machining. 追加加工后的总长							
Number of circuit 循环数	2.7 × 1	<table border="1"> <thead> <tr> <th>Support-unit Recommendation 推荐的支架组件</th> <th>Supported-side 支撑侧</th> <th>Fixed-side 固定侧</th> </tr> </thead> <tbody> <tr> <td></td> <td>—</td> <td>MSU-4C/4G</td> </tr> </tbody> </table>		Support-unit Recommendation 推荐的支架组件	Supported-side 支撑侧	Fixed-side 固定侧		—	MSU-4C/4G
Support-unit Recommendation 推荐的支架组件	Supported-side 支撑侧	Fixed-side 固定侧							
	—	MSU-4C/4G							
Shaft, Nut material 轴、螺母材质	SCM415H	D-type: Other than the above. 上述以外的形状							
Surface hardness 螺纹部表面硬度	HRC58~62 (Thread area)								
Anti-rust treatment 防锈处理	Anti-rust oil 防锈油								

Unit(单位):mm

Ball Screw Model 滚珠丝杠型号	Travel 行程	Grade 精度	Shaft length 丝杠轴长度				Lead accuracy 导程精度		Total Run-out 全跳动	Axial play 轴向间隙	Preload Torque 预压扭矩 Nm	Basic Load Rating 基本额定负载 N	
			L ₁	L ₂	L ₃	L ₄	Travel deviation 代表移动量误差 e _p	Variation 波动 V _u				Dynamic 额定动负载 Ca	Static 额定静负载 Coa
SG0300.5-038R070C3	25	C3	38	41	47	70	± 0.008	0.008	0.025	~0.005	—	150	220

Note) Please refer to page A206 for order code of end-journal machining. 注) 追加加工的公称型号指定方式请参照A206页。

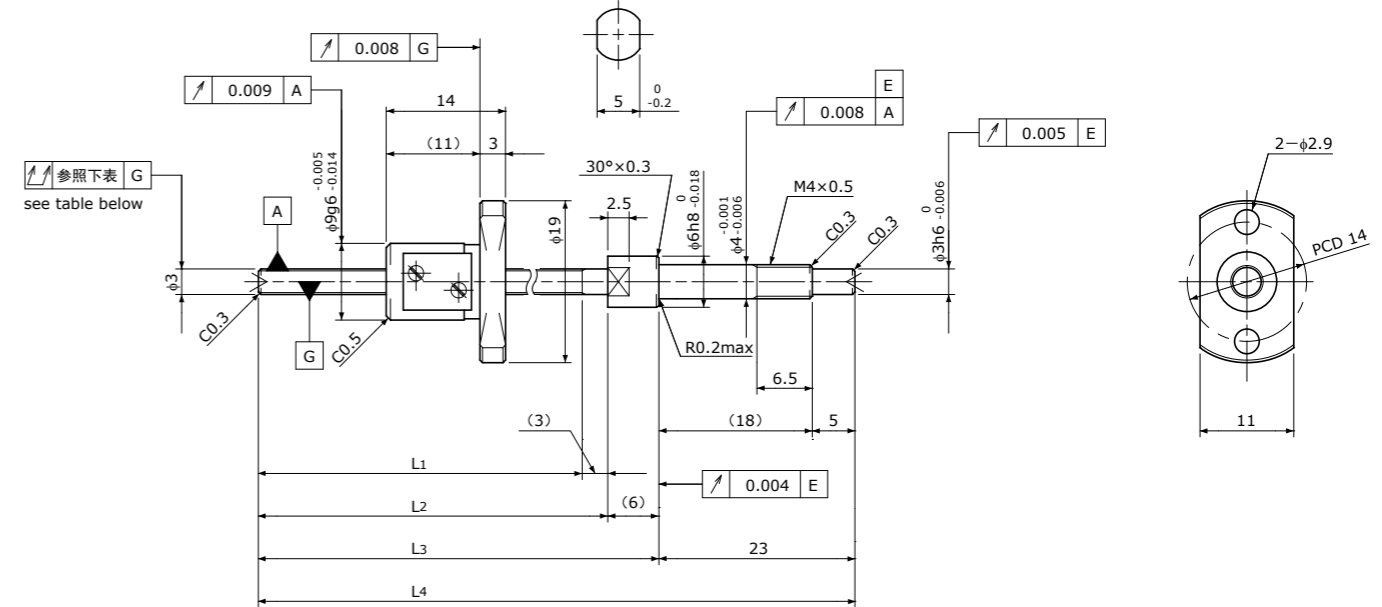
Standard products in stock SG series
标准库存品 SG系列SG0301 | Shaft dia.(轴径) $\phi 3$ Lead(导程)1mm | C3

Unit(单位):mm

Ball Screw Specifications 主要技术参数		Supported-side end-journal profile 支撑侧轴端加工形状							
Ball size 钢珠直径	$\phi 0.6$	A-type							
Number of thread 螺纹条数	1								
Thread direction 螺纹旋向	Right 右旋	$L_5 = L_6 - 32$ L_6							
Shaft root dia. 丝杠轴底径	$\phi 2.4$	L ₅ : Thread length after end-journal machining. 追加加工后的螺纹部长度 L ₆ : Total length after end-journal machining. 追加加工后的总长							
Number of circuit 循环数	3.7 × 1	<table border="1"> <thead> <tr> <th>Support-unit Recommendation 推荐的支架组件</th> <th>Supported-side 支撑侧</th> <th>Fixed-side 固定侧</th> </tr> </thead> <tbody> <tr> <td></td> <td>—</td> <td>MSU-4C/4G</td> </tr> </tbody> </table>		Support-unit Recommendation 推荐的支架组件	Supported-side 支撑侧	Fixed-side 固定侧		—	MSU-4C/4G
Support-unit Recommendation 推荐的支架组件	Supported-side 支撑侧	Fixed-side 固定侧							
	—	MSU-4C/4G							
Shaft, Nut material 轴、螺母材质	SCM415H	D-type: Other than the above. 上述以外的形状							
Surface hardness 螺纹部表面硬度	HRC58~62 (Thread area)								
Anti-rust treatment 防锈处理	Anti-rust oil 防锈油								

Unit(单位):mm

Ball Screw Model 滚珠丝杠型号	Travel 行程	Grade 精度	Shaft length 丝杠轴长度				Lead accuracy 导程精度		Total Run-out 全跳动	Axial play 轴向间隙	Preload Torque 预压扭矩 Nm	Basic Load Rating 基本额定负载 N	
			L ₁	L ₂	L ₃	L ₄	Travel deviation 代表移动量误差 e _p	Variation 波动 V _u				Dynamic 额定动负载 Ca	Static 额定静负载 Coa
SG0301-038R070C3	20	C3	38	41	47	70	± 0.008	0.008	0.025	~0.005	—	330	440

Note) Please refer to page A206 for order code of end-journal machining. 注) 追加加工的公称型号指定方式请参照A206页。

Standard products in stock SG series
标准库存品 SG系列

SG0401 | Shaft dia.(轴径) $\phi 4$ Lead(导程)1mm | C3&C5

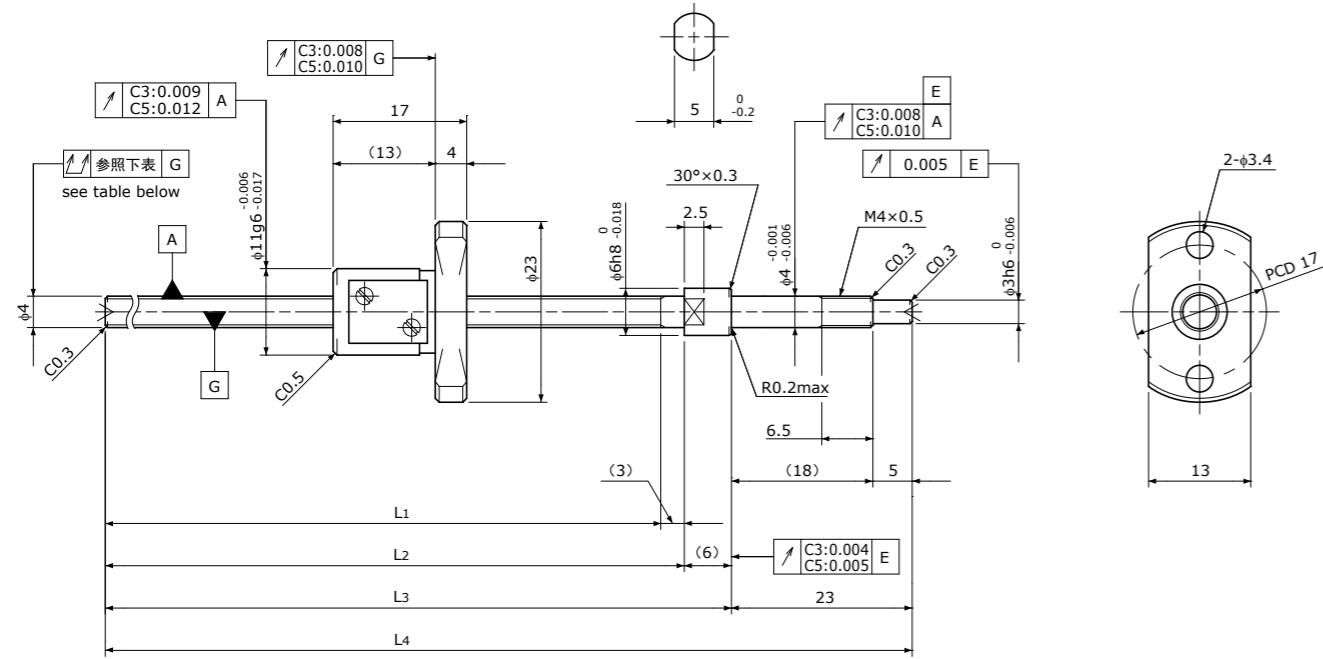

Unit(单位):mm

Ball Screw Specifications 主要技术参数	
Ball size 钢珠直径	$\phi 0.8$
Number of thread 螺纹条数	1
Thread direction 螺纹旋向	Right 右旋
Shaft root dia. 丝杠轴底径	$\phi 3.3$
Number of circuit 循环数	3.7×1
Shaft, Nut material 轴、螺母材质	SCM415H
Surface hardness 螺纹部表面硬度	HRC58~62 (Thread area)
Anti-rust treatment 防锈处理	Anti-rust oil 防锈油

Supported-side end-journal profile 支撑侧轴端加工形状

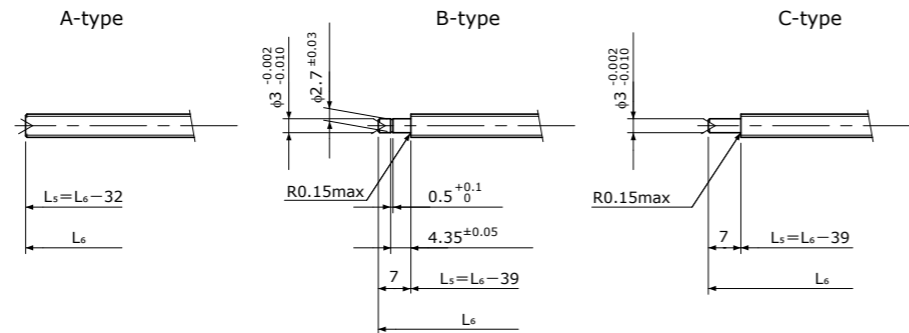

L₅: Thread length after end-journal machining. 追加加工后的螺纹部长度
L₆: Total length after end-journal machining. 追加加工后的总长

Support-unit Recommendation 推荐的支架组件	Supported-side 支撑侧	Fixed-side 固定侧
	MSU-4CS/4GS	MSU-4C/4G

D-type: Other than the above. 上述以外的形状

Unit(单位):mm

Ball Screw Model 滚珠丝杠型号	Travel 行程	Grade 精度	Shaft length 丝杠轴长度				Lead accuracy 导程精度		Total Run-out 全跳动	Axial play 轴向间隙	Preload Torque 预压扭矩 Nm	Basic Load Rating 基本额定负载 N	
			L ₁	L ₂	L ₃	L ₄	Travel deviation 代表移动量误差 e _p	Variation 波动 V _u				Dynamic 额定动负载 Ca	Static 额定静负载 Coa
SG0401-063R095C3	45	C3	63	66	72	95	± 0.008	0.008	0.025	0	~0.004	350	400
SG0401-083R115C3	65	C3	83	86	92	115	± 0.008	0.008	0.025				
SG0401-103R135C3	85	C3	103	106	112	135	± 0.010	0.008	0.035				
SG0401-063R095C5	45	C5	63	66	72	95	± 0.018	0.018	0.035	~0.005	—	560	790
SG0401-083R115C5	65	C5	83	86	92	115	± 0.018	0.018	0.035				
SG0401-103R135C5	85	C5	103	106	112	135	± 0.020	0.018	0.050				

Note) Please refer to page A206 for order code of end-journal machining. 注) 追加加工的公称型号指定方式请参照A206页。

Standard products in stock SG series
标准库存品 SG系列

SG0402 | Shaft dia.(轴径) $\phi 4$ Lead(导程)2mm | C3

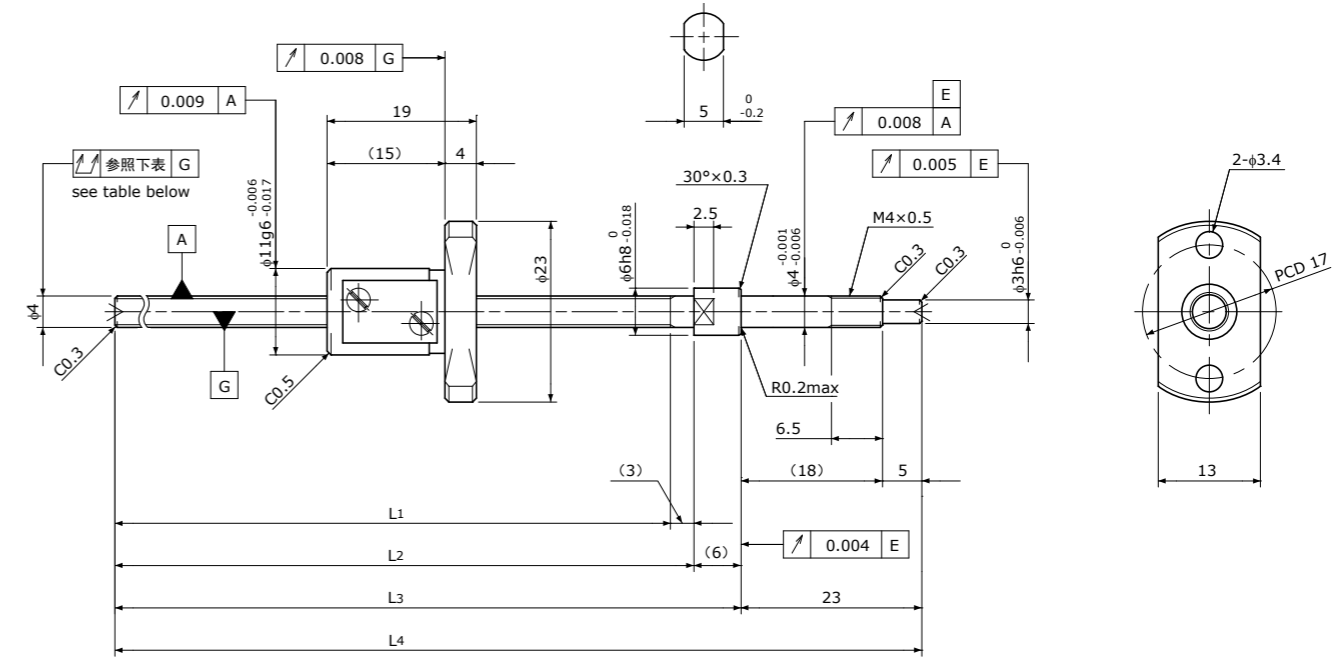

Unit(单位):mm

Ball Screw Specifications 主要技术参数	
Ball size 钢珠直径	$\phi 0.8$
Number of thread 螺纹条数	1
Thread direction 螺纹旋向	Right 右旋
Shaft root dia. 丝杠轴底径	$\phi 3.3$
Number of circuit 循环数	2.7×1
Shaft, Nut material 轴、螺母材质	SCM415H
Surface hardness 螺纹部表面硬度	HRC58~62 (Thread area)
Anti-rust treatment 防锈处理	Anti-rust oil 防锈油

Supported-side end-journal profile 支撑侧轴端加工形状

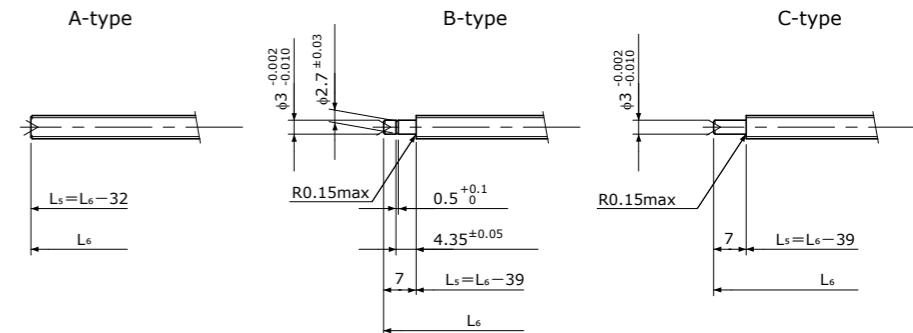

L₅: Thread length after end-journal machining. 追加加工后的螺纹部长度
L₆: Total length after end-journal machining. 追加加工后的总长

Support-unit Recommendation 推荐的支架组件	Supported-side 支撑侧	Fixed-side 固定侧
	MSU-4CS/4GS	MSU-4C/4G

D-type: Other than the above. 上述以外的形状

Unit(单位):mm

Ball Screw Model 滚珠丝杠型号	Travel 行程	Grade 精度	Shaft length 丝杠轴长度				Lead accuracy 导程精度		Total Run-out 全跳动	Axial play 轴向间隙	Preload Torque 预压扭矩 Nm	Basic Load Rating 基本额定负载 N	
			L ₁	L ₂	L ₃	L ₄	Travel deviation 代表移动量误差 e _p	Variation 波动 V _u				Dynamic 额定动负载 Ca	Static 额定静负载 Coa
SG0402-103R135C3	80	C3	103	106	112	135	± 0.010	0.008	0.035	~0.005	—	420	570

Note) Please refer to page A206 for order code of end-journal machining. 注) 追加加工的公称型号指定方式请参照A206页。

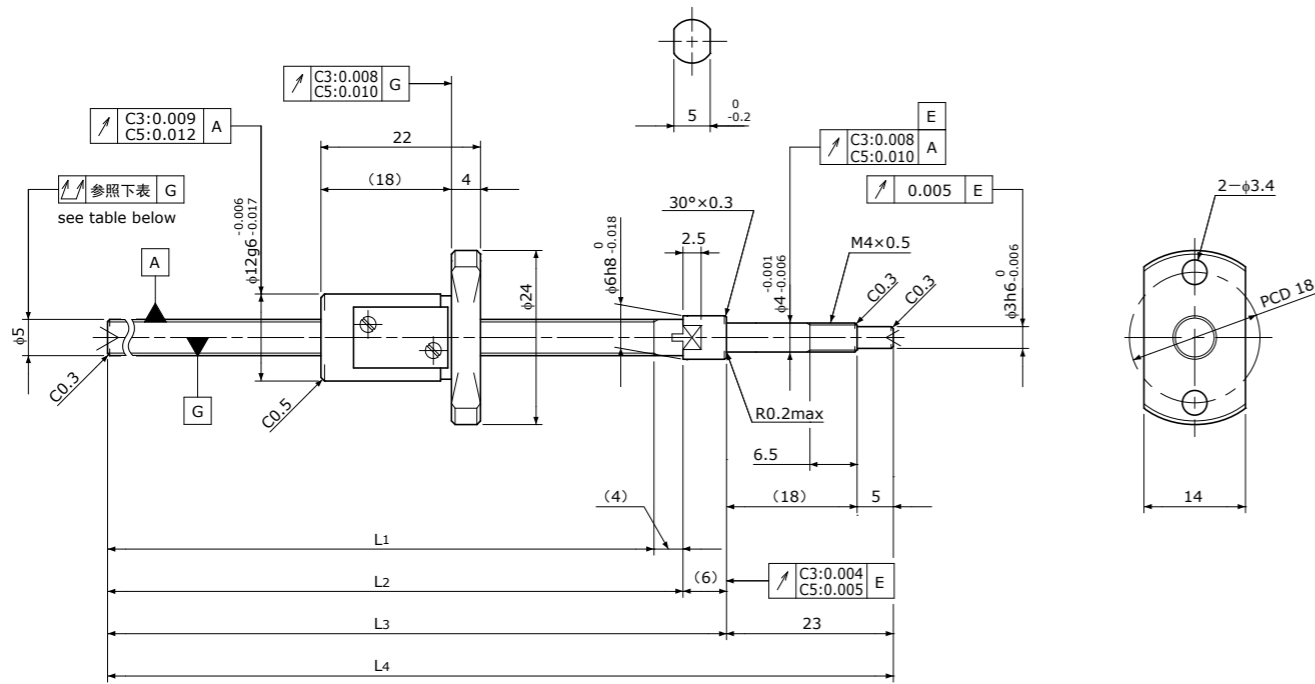
Standard products in stock SG series
标准库存品 SG系列SG0504 | Shaft dia.(轴径) $\phi 5$ Lead(导程)4mm | C3&C5

Unit(单位):mm

Ball Screw Specifications	主要技术参数
Ball size 钢珠直径	$\phi 0.8$
Number of thread 螺纹条数	1
Thread direction 螺纹旋向	Right 右旋
Shaft root dia. 丝杠轴底径	$\phi 4.3$
Number of circuit 循环数	2.7×1
Shaft, Nut material 轴、螺母材质	SCM415H
Surface hardness 螺纹部表面硬度	HRC58~62 (Thread area)
Anti-rust treatment 防锈处理	Anti-rust oil 防锈油

Supported-side end-journal profile	支撑侧轴端加工形状
A-type	B-type
C-type	

L_5 : Thread length after end-journal machining. 追加加工后的螺纹部长度
 L_6 : Total length after end-journal machining. 追加加工后的总长

Support-unit Recommendation	Supported-side 支撑侧	固定侧
推荐的支架组件	MSU-4CS/4GS	MSU-4C/4G

D-type: Other than the above. 上述以外的形状

Unit(单位):mm

Ball Screw Model	Travel 行程	Grade 精度	Shaft length 丝杠轴长度				Lead accuracy 导程精度		Total Run-out 全跳动	Axial play 轴向间隙	Preload Torque 预压扭矩 Nm	Basic Load Rating 基本额定负载 N	
			L_1	L_2	L_3	L_4	Travel deviation 代表移动量误差 e_p	Variation 波动 V_u				Dynamic 额定动负载 C_a	Static 额定静负载 C_oa
SG0504-062R095C3	40	C3	62	66	72	95	± 0.008	0.008	0.025	0 Spacer Ball 间隔钢珠 (1:1)	~0.005	300	360
SG0504-112R145C3	90	C3	112	116	122	145	± 0.010	0.008	0.035			470	720
SG0504-062R095C5	40	C5	62	66	72	95	± 0.018	0.018	0.035	~0.005	—	470	720
SG0504-112R145C5	90	C5	112	116	122	145	± 0.020	0.018	0.050			—	—

Note) Please refer to page A206 for order code of end-journal machining. 注) 追加加工的公称型号指定方式请参照A206页。

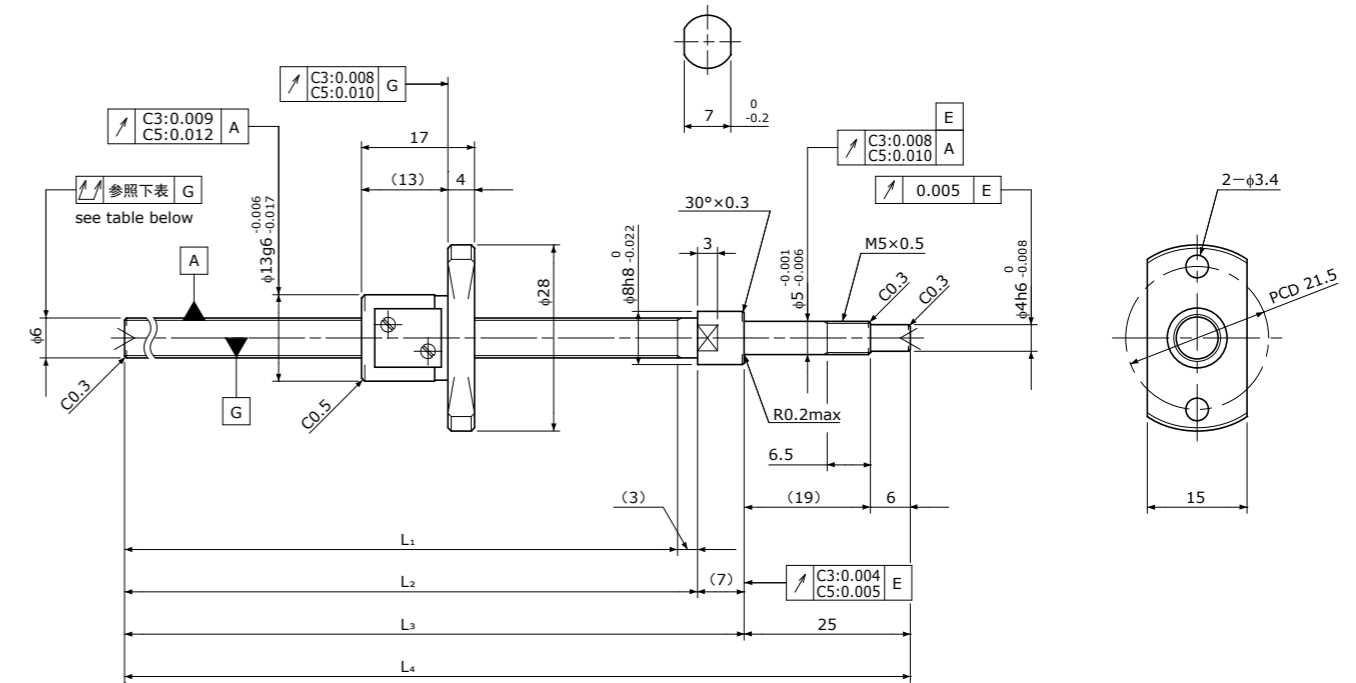
Standard products in stock SG series
标准库存品 SG系列SG0601 | Shaft dia.(轴径) $\phi 6$ Lead(导程)1mm | C3&C5

Unit(单位):mm

Ball Screw Specifications	主要技术参数
Ball size 钢珠直径	$\phi 0.8$
Number of thread 螺纹条数	1
Thread direction 螺纹旋向	Right 右旋
Shaft root dia. 丝杠轴底径	$\phi 5.3$
Number of circuit 循环数	3.7×1
Shaft, Nut material 轴、螺母材质	SCM415H
Surface hardness 螺纹部表面硬度	HRC58~62 (Thread area)
Anti-rust treatment 防锈处理	Anti-rust oil 防锈油

Supported-side end-journal profile	支撑侧轴端加工形状
A-type	B-type
C-type	

L_5 : Thread length after end-journal machining. 追加加工后的螺纹部长度
 L_6 : Total length after end-journal machining. 追加加工后的总长

Support-unit Recommendation	Supported-side 支撑侧	固定侧
推荐的支架组件	MSU-5CS/5GS	MSU-5C/5G

D-type: Other than the above. 上述以外的形状

Unit(单位):mm

Ball Screw Model	Travel 行程	Grade 精度	Shaft length 丝杠轴长度				Lead accuracy 导程精度		Total Run-out 全跳动	Axial play 轴向间隙	Preload Torque 预压扭矩 Nm	Basic Load Rating 基本额定负载 N	
			L_1	L_2	L_3	L_4	Travel deviation 代表移动量误差 e_p	Variation 波动 V_u				Dynamic 额定动负载 C_a	Static 额定静负载 C_oa
SG0601-085R120C3	65	C3	85	88	95	120	± 0.008	0.008	0.025	0 Spacer Ball 间隔钢珠 (1:1)	~0.006	430	610
SG0601-110R145C3	90	C3	110	113	120	145	± 0.010	0.008	0.035			680	1200
SG0601-135R170C3	115	C3	135	138	145	170	± 0.010	0.008	0.035	~0.005	—	680	1200
SG0601-085R120C5	65	C5	85	88	95	120	± 0.018	0.018	0.035			—	—
SG0601-110R145C5	90	C5	110	113	120	145	± 0.020	0.018	0.050	—	—		
SG0601-135R170C5	115	C5	135	138	145	170	± 0.020	0.018	0.050	—	—		

Note) Please refer to page A206 for order code of end-journal machining. 注) 追加加工的公称型号指定方式请参照A206页。

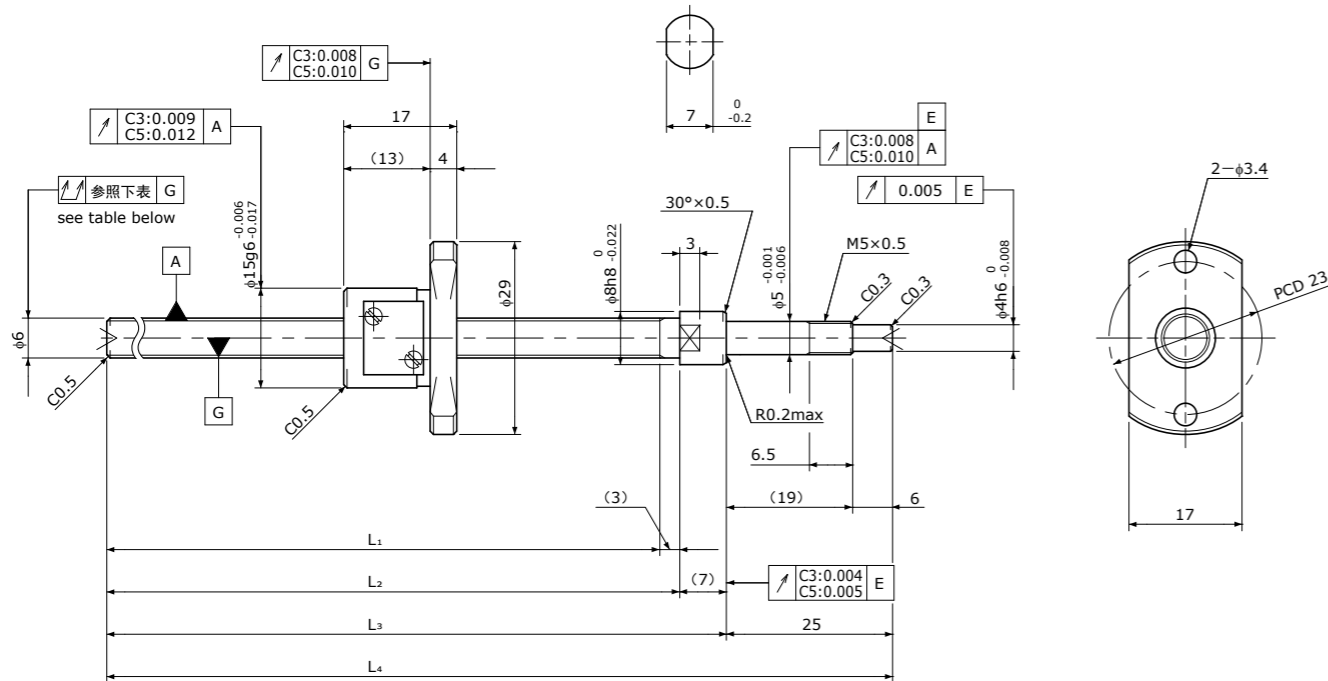
Standard products in stock SG series
标准库存品 SG系列SG0602 | Shaft dia.(轴径) $\phi 6$ Lead(导程)2mm | C3&C5

Unit(单位):mm

Ball Screw Specifications	主要技术参数
Ball size 钢珠直径	$\phi 1.0$
Number of thread 螺纹条数	1
Thread direction 螺纹旋向	Right 右旋
Shaft root dia. 丝杠轴底径	$\phi 5.1$
Number of circuit 循环数	2.7×1
Shaft, Nut material 轴、螺母材质	SCM415H
Surface hardness 螺纹部表面硬度	HRC58~62 (Thread area)
Anti-rust treatment 防锈处理	Anti-rust oil 防锈油

Supported-side end-journal profile 支撑侧轴端加工形状

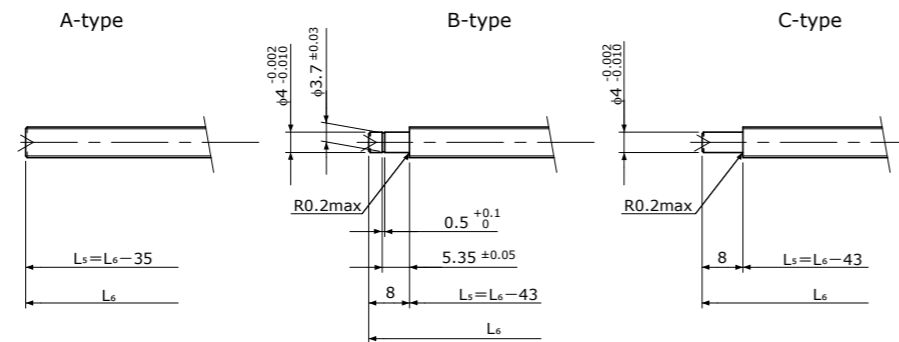

L_s : Thread length after end-journal machining. 追加加工后的螺纹部长度
 L_6 : Total length after end-journal machining. 追加加工后的总长

Support-unit Recommendation	Supported-side 支撑侧	Fixed-side 固定侧
推荐的支架组件	MSU-5CS/5GS	MSU-5C/5G

D-type: Other than the above. 上述以外的形状

Unit(单位):mm

Ball Screw Model 滚珠丝杠型号	Travel 行程	Grade 精度	Shaft length 丝杠轴长度				Lead accuracy 导程精度		Total Run-out 全跳动	Axial play 轴向间隙	Preload Torque 预压扭矩 Nm	Basic Load Rating 基本额定负载 N	
			L_1	L_2	L_3	L_4	Travel deviation 代表移动量误差 e_p	Variation 波动 V_u				Dynamic 额定动负载 C_a	Static 额定静负载 C_oa
SG0602-085R120C3	65	C3	85	88	95	120	± 0.008	0.008	0.025	0 Spacer Ball 间隔钢珠 (1:1)	0.003~ 0.007	470	590
SG0602-135R170C3	115	C3	135	138	145	170	± 0.010	0.008	0.035				
SG0602-085R120C5	65	C5	85	88	95	120	± 0.018	0.018	0.035	~0.005	—	750	1200
SG0602-135R170C5	115	C5	135	138	145	170	± 0.020	0.018	0.050				

Note) Please refer to page A206 for order code of end-journal machining. 注) 追加加工的公称型号指定方式请参照A206页。

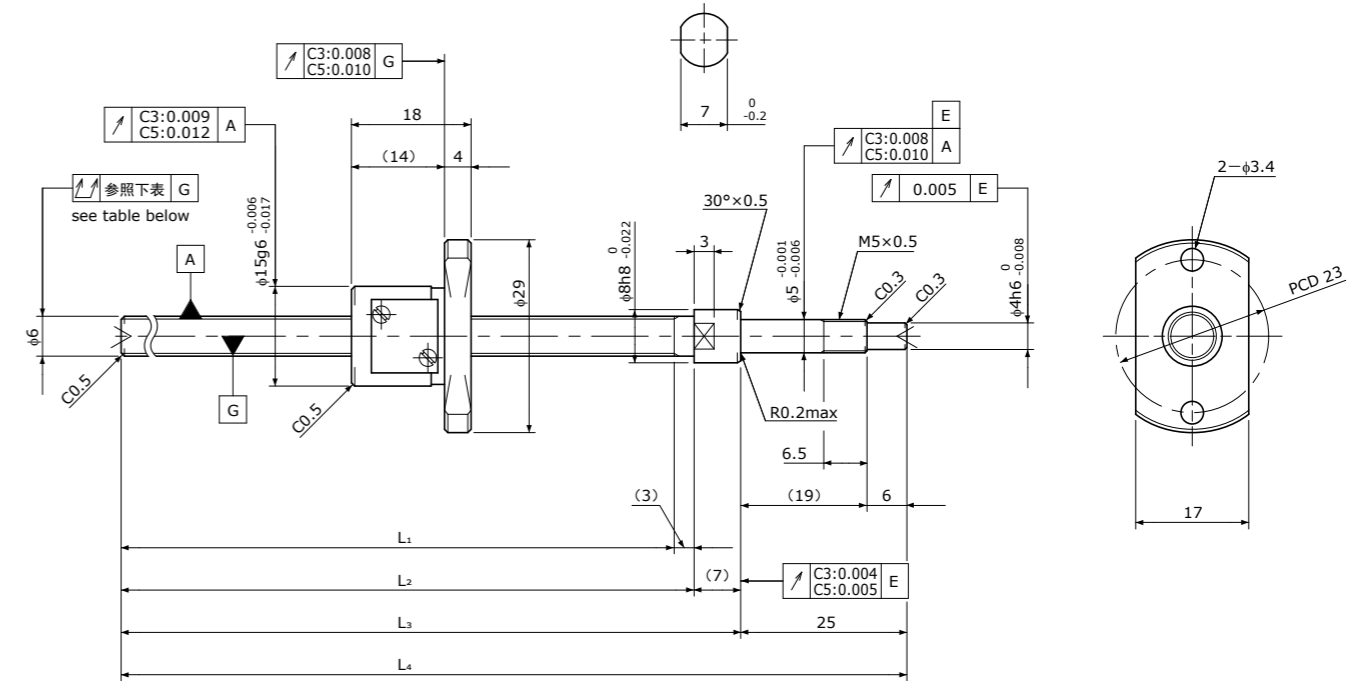
Standard products in stock SG series
标准库存品 SG系列SG0602.5 | Shaft dia.(轴径) $\phi 6$ Lead(导程)2.5mm | C3&C5

Unit(单位):mm

Ball Screw Specifications	主要技术参数
Ball size 钢珠直径	$\phi 1.0$
Number of thread 螺纹条数	1
Thread direction 螺纹旋向	Right 右旋
Shaft root dia. 丝杠轴底径	$\phi 5.1$
Number of circuit 循环数	2.7×1
Shaft, Nut material 轴、螺母材质	SCM415H
Surface hardness 螺纹部表面硬度	HRC58~62 (Thread area)
Anti-rust treatment 防锈处理	Anti-rust oil 防锈油

Supported-side end-journal profile 支撑侧轴端加工形状

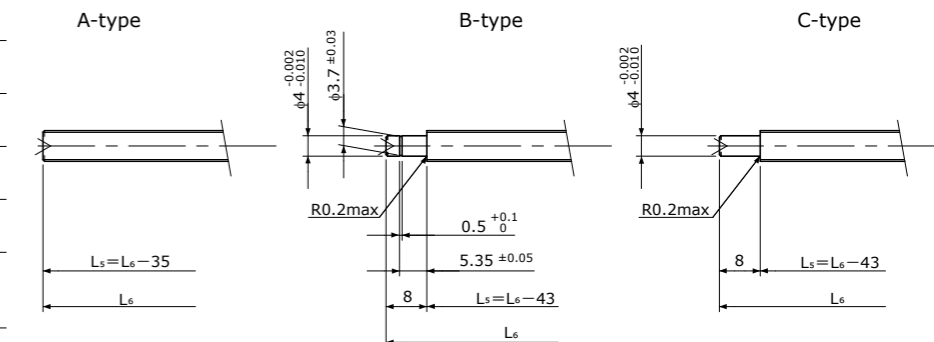

L_s : Thread length after end-journal machining. 追加加工后的螺纹部长度
 L_6 : Total length after end-journal machining. 追加加工后的总长

Support-unit Recommendation	Supported-side 支撑侧	Fixed-side 固定侧
推荐的支架组件	MSU-5CS/5GS	MSU-5C/5G

D-type: Other than the above. 上述以外的形状

Unit(单位):mm

Ball Screw Model 滚珠丝杠型号	Travel 行程	Grade 精度	Shaft length 丝杠轴长度				Lead accuracy 导程精度		Total Run-out 全跳动	Axial play 轴向间隙	Preload Torque 预压扭矩 Nm	Basic Load Rating 基本额定负载 N	
			L_1	L_2	L_3	L_4	Travel deviation 代表移动量误差 e_p	Variation 波动 V_u				Dynamic 额定动负载 C_a	Static 额定静负载 C_oa
SG0602.5-085R120C3	65	C3	85	88	95	120	± 0.008	0.008	0.025	0 Spacer Ball 间隔钢珠 (1:1)	0.003~ 0.007	470	590
SG0602.5-135R170C3	115	C3	135	138	145	170	± 0.010	0.008	0.035				
SG0602.5-085R120C5	65	C5	85	88	95	120	± 0.018	0.018	0.035	~0.005	—	750	1200
SG0602.5-135R170C5	115	C5	135	138	145	170	± 0.020	0.018	0.050				

Note) Please refer to page A206 for order code of end-journal machining. 注) 追加加工的公称型号指定方式请参照A206页。

Standard products in stock SG series
标准库存品 SG系列

SG0606

Shaft dia.(轴径) $\phi 6$ Lead(导程)6mm

C5

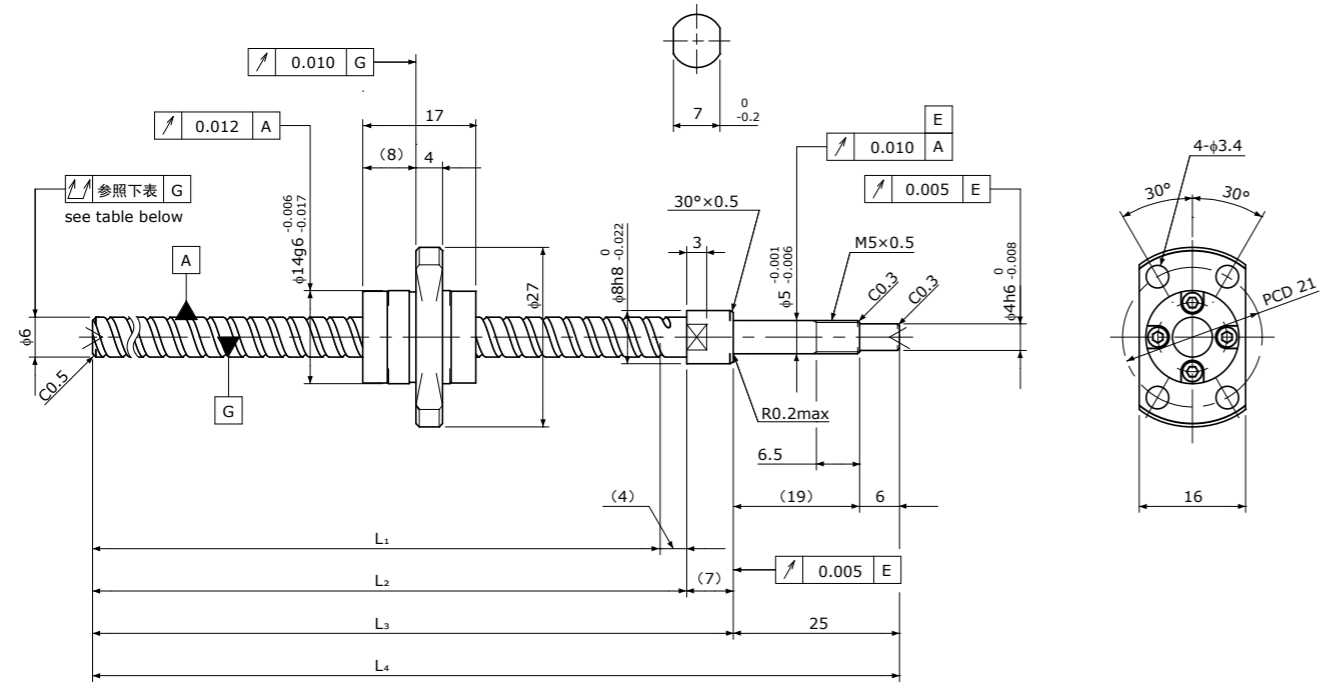

Standard products in stock SG series
标准库存品 SG系列

SG0610

Shaft dia.(轴径) $\phi 6$ Lead(导程)10mm

C5

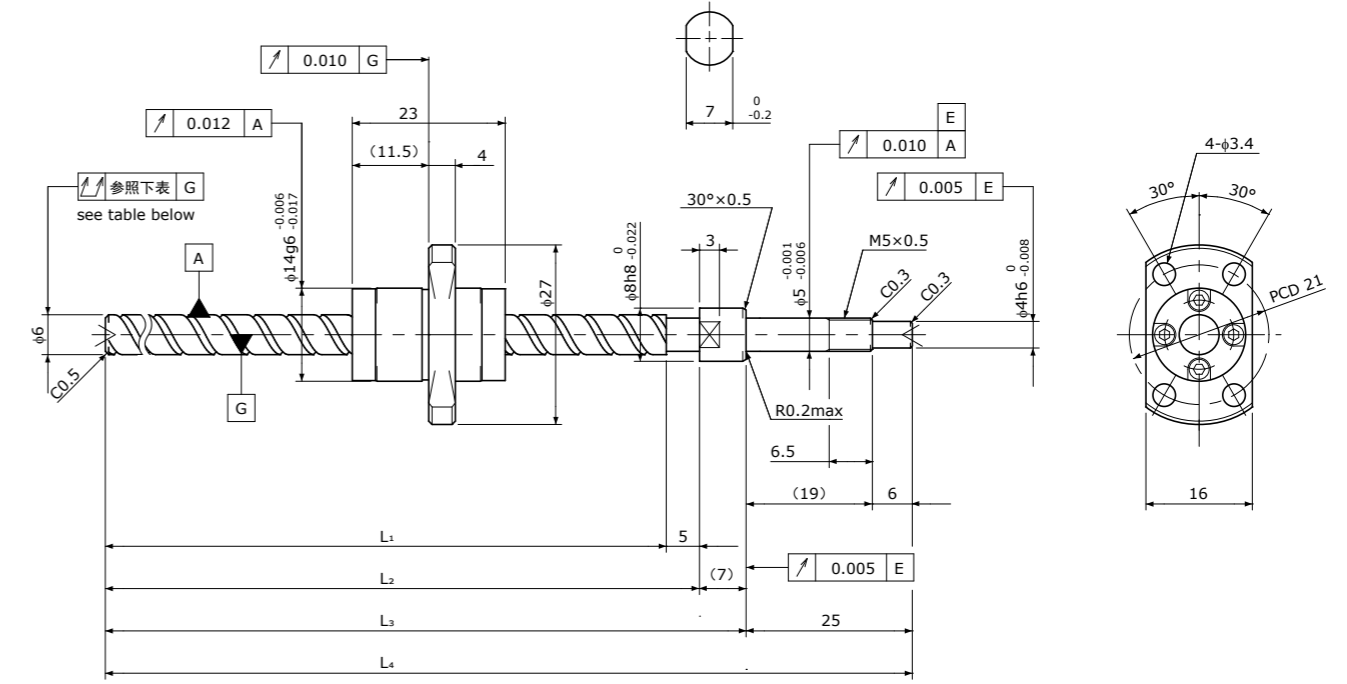

Unit(单位):mm

Ball Screw Specifications 主要技术参数	
Ball size 钢珠直径	$\phi 1.0$
Number of thread 螺纹条数	2
Thread direction 螺纹旋向	Right 右旋
Shaft root dia. 丝杠轴底径	$\phi 5.2$
Number of circuit 循环数	1.6×2
Shaft, Nut material 轴、螺母材质	SCM415H
Surface hardness 螺纹部表面硬度	HRC58~62 (Thread area)
Anti-rust treatment 防锈处理	Anti-rust oil 防锈油

Supported-side end-journal profile 支撑侧轴端加工形状		
A-type	B-type	C-type
$L_5 = L_6 - 36$	$L_5 = L_6 - 44$	$L_5 = L_6 - 44$
L ₅ : Thread length after end-journal machining. 追加加工后的螺纹部长度 L ₆ : Total length after end-journal machining. 追加加工后的总长		
Support-unit Recommendation 推荐的支架组件	Supported-side 支撑侧 : Fixed-side 固定侧 :	MSU-5CS/5GS MSU-5C/5G
D-type : Other than the above. 上述以外的形状		

Unit(单位):mm

Ball Screw Model 滚珠丝杠型号	Travel 行程	Grade 精度	Shaft length 丝杠轴长度				Lead accuracy 导程精度		Total Run-out 全跳动	Axial play 轴向间隙	Preload Torque 预压扭矩 Nm	Basic Load Rating 基本额定负载 N	
			L ₁	L ₂	L ₃	L ₄	Travel deviation 代表移动量误差 e _p	Variation 波动 V _u				Dynamic 额定动负载 Ca	Static 额定静负载 Coa
SG0606-084R120C5	65	C5	84	88	95	120	± 0.018	0.018	0.035	~0.005	—	870	1450
SG0606-134R170C5	115	C5	134	138	145	170	± 0.020	0.018	0.050				

Note) Please refer to page A206 for order code of end-journal machining. 注) 追加加工的公称型号指定方式请参照A206页。

Unit(单位):mm

Ball Screw Specifications 主要技术参数	
Ball size 钢珠直径	$\phi 1.2$
Number of thread 螺纹条数	2
Thread direction 螺纹旋向	Right 右旋
Shaft root dia. 丝杠轴底径	$\phi 5.0$
Number of circuit 循环数	1.2×2
Shaft, Nut material 轴、螺母材质	SCM415H
Surface hardness 螺纹部表面硬度	HRC58~62 (Thread area)
Anti-rust treatment 防锈处理	Anti-rust oil 防锈油

Supported-side end-journal profile 支撑侧轴端加工形状		
A-type	B-type	C-type
$L_5 = L_6 - 37$	$L_5 = L_6 - 45$	$L_5 = L_6 - 45$
L ₅ : Thread length after end-journal machining. 追加加工后的螺纹部长度 L ₆ : Total length after end-journal machining. 追加加工后的总长		
Support-unit Recommendation 推荐的支架组件	Supported-side 支撑侧 : Fixed-side 固定侧 :	MSU-5CS/5GS MSU-5C/5G
D-type : Other than the above. 上述以外的形状		

Unit(单位):mm

Ball Screw Model 滚珠丝杠型号	Travel 行程	Grade 精度	Shaft length 丝杠轴长度				Lead accuracy 导程精度		Total Run-out 全跳动	Axial play 轴向间隙	Preload Torque 预压扭矩 Nm	Basic Load Rating 基本额定负载 N	
			L ₁	L ₂	L ₃	L ₄	Travel deviation 代表移动量误差 e _p	Variation 波动 V _u				Dynamic 额定动负载 Ca	Static 额定静负载 Coa
SG0610-133R170C5	110	C5	133	138	145	170	± 0.020	0.018	0.050	~0.005	—	950	1600

Note) Please refer to page A206 for order code of end-journal machining. 注) 追加加工的公称型号指定方式请参照A206页。

Standard products in stock SG series
标准库存品 SG系列

SG0801

Shaft dia.(轴径)φ8 Lead(导程)1mm

C3&C5

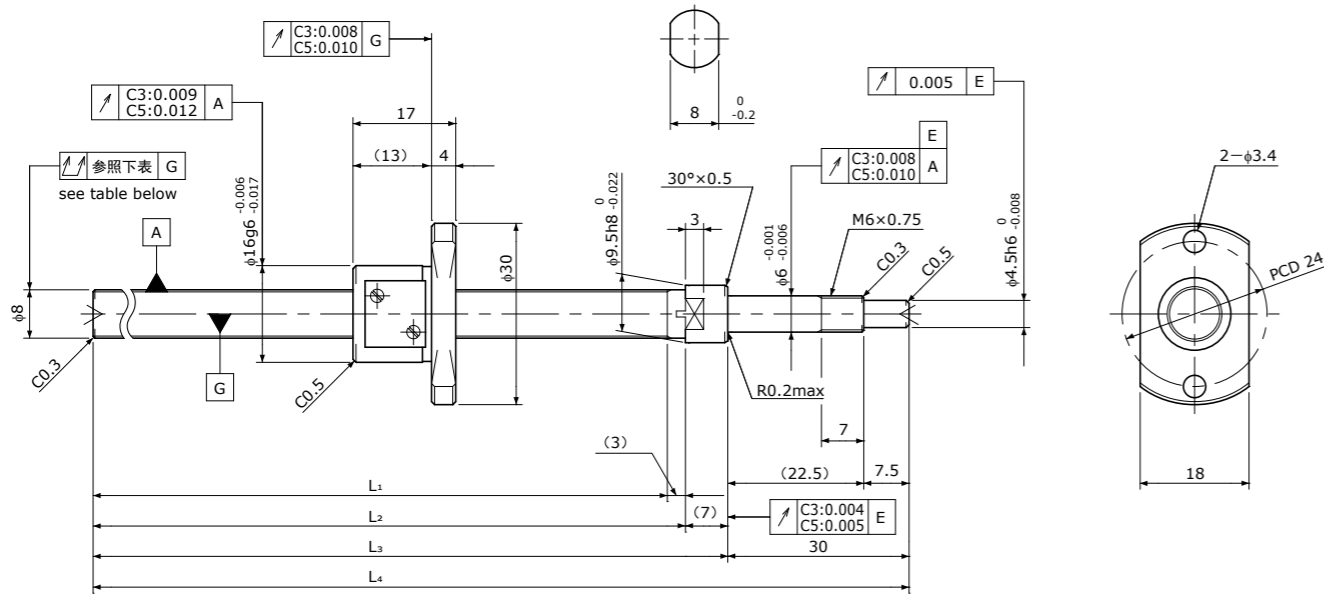

Unit(单位):mm

Ball Screw Specifications 主要技术参数	
Ball size 钢珠直径	φ0.8
Number of thread 螺纹条数	1
Thread direction 螺纹旋向	Right 右旋
Shaft root dia. 丝杠轴底径	φ7.3
Number of circuit 循环数	3.7×1
Shaft, Nut material 轴、螺母材质	SCM415H
Surface hardness 螺纹部表面硬度	HRC58~62 (Thread area)
Anti-rust treatment 防锈处理	Anti-rust oil 防锈油

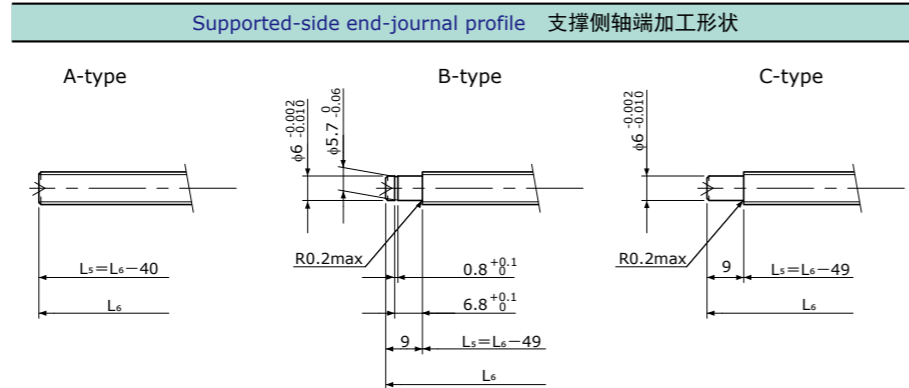

L_s : Thread length after end-journal machining. 追加加工后的螺纹部长度
 L_6 : Total length after end-journal machining. 追加加工后的总长

Support-unit Recommendation 推荐的支架组件	Supported-side 支撑侧	Fixed-side 固定侧
	MSU-6CS/6GS	MSU-6C/6G

D-type: Other than the above. 上述以外的形状

Unit(单位):mm

Ball Screw Model 滚珠丝杠型号	Travel 行程	Grade 精度	Shaft length 丝杠轴长度				Lead accuracy 导程精度		Total Run-out 全跳动	Axial play 轴向间隙	Preload Torque 预压扭矩 Nm	Basic Load Rating 基本额定负载 N	
			L ₁	L ₂	L ₃	L ₄	Travel deviation 代表移动量误差 e_p	Variation 波动 V_u				Dynamic 额定动负载 C_a	Static 额定静负载 C_oa
SG0801-100R140C3	80	C3	100	103	110	140	±0.008	0.008	0.035	0 Spacer Ball 间隔钢珠 (1:1)	0.002~ 0.008	490	820
SG0801-130R170C3	110	C3	130	133	140	170	±0.010	0.008	0.035				
SG0801-160R200C3	140	C3	160	163	170	200	±0.010	0.008	0.035				
SG0801-210R250C3	190	C3	210	213	220	250	±0.012	0.008	0.050				
SG0801-100R140C5	80	C5	100	103	110	140	±0.018	0.018	0.050	~0.005	—	780	1650
SG0801-130R170C5	110	C5	130	133	140	170	±0.020	0.018	0.050				
SG0801-160R200C5	140	C5	160	163	170	200	±0.020	0.018	0.050				
SG0801-210R250C5	190	C5	210	213	220	250	±0.023	0.018	0.065				

Note) Please refer to page A206 for order code of end-journal machining. 注)追加加工的公称型号指定方式请参照A206页。

Standard products in stock SG series
标准库存品 SG系列

SG0802

Shaft dia.(轴径)φ8 Lead(导程)2mm

C3&C5

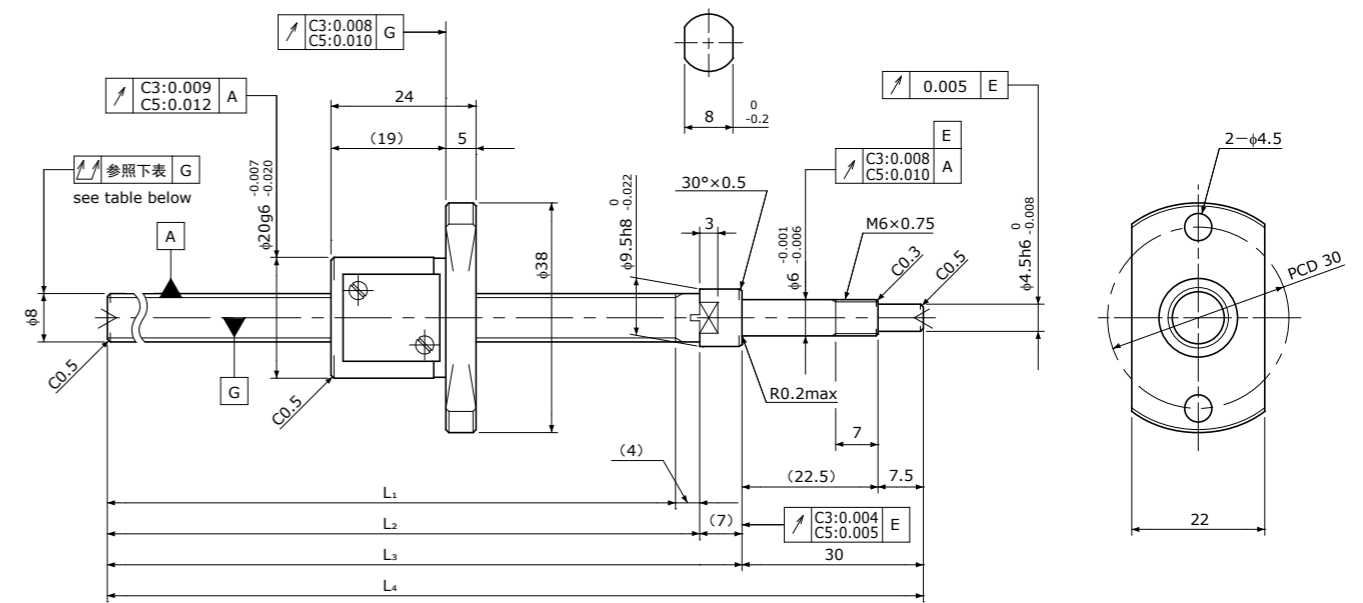

Unit(单位):mm

Ball Screw Specifications 主要技术参数	
Ball size 钢珠直径	φ1.5875
Number of thread 螺纹条数	1
Thread direction 螺纹旋向	Right 右旋
Shaft root dia. 丝杠轴底径	φ6.6
Number of circuit 循环数	3.7×1
Shaft, Nut material 轴、螺母材质	SCM415H
Surface hardness 螺纹部表面硬度	HRC58~62 (Thread area)
Anti-rust treatment 防锈处理	Anti-rust oil 防锈油

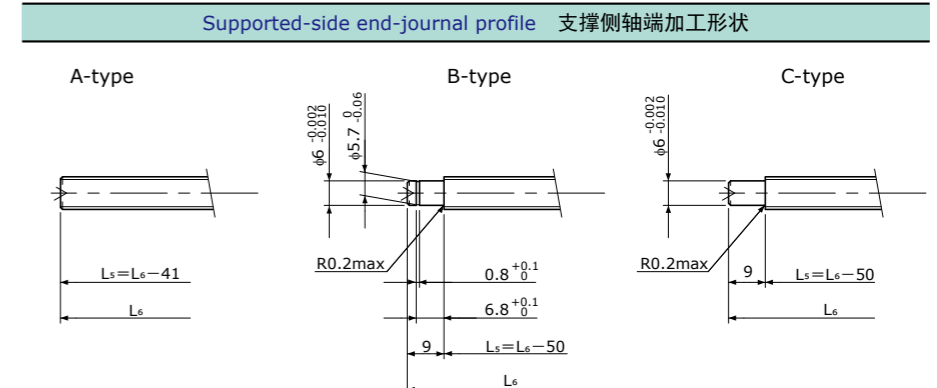

L_s : Thread length after end-journal machining. 追加加工后的螺纹部长度
 L_6 : Total length after end-journal machining. 追加加工后的总长

Support-unit Recommendation 推荐的支架组件	Supported-side 支撑侧	Fixed-side 固定侧
	MSU-6CS/6GS	MSU-6C/6G

D-type: Other than the above. 上述以外的形状

Unit(单位):mm

Ball Screw Model 滚珠丝杠型号	Travel 行程	Grade 精度	Shaft length 丝杠轴长度				Lead accuracy 导程精度		Total Run-out 全跳动	Axial play 轴向间隙	Preload Torque 预压扭矩 Nm	Basic Load Rating 基本额定负载 N	
			L ₁	L ₂	L ₃	L ₄	Travel deviation 代表移动量误差 e_p	Variation 波动 V_u				Dynamic 额定动负载 C_a	Static 额定静负载 C_oa
SG0802-099R140C3	75	C3	99	103	110	140	±0.008	0.008	0.035	0 Spacer Ball 间隔钢珠 (1:1)	0.004~ 0.020	1550	2100
SG0802-129R170C3	105	C3	129	133	140	170	±0.010	0.008	0.035				
SG0802-159R200C3	135	C3	159	163	170	200	±0.010	0.008	0.035				
SG0802-209R250C3	185	C3	209	213	220	250	±0.012	0.008	0.050				
SG0802-099R140C5	75	C5	99	103	110	140	±0.018	0.018	0.050	~0.005	—	2400	4100
SG0802-129R170C5	105	C5	129	133	140	170	±0.020	0.018	0.050				
SG0802-159R200C5	135	C5	159	163	170	200	±0.020	0.018	0.050				
SG0802-209R250C5	185	C5	209	213	220	250	±0.023	0.018	0.065				

Note) Please refer to page A206 for order code of end-journal machining. 注)追加加工的公称型号指定方式请参照A206页。

Standard products in stock SG series
标准库存品 SG系列

SG0804 | Shaft dia.(轴径) $\phi 8$ Lead(导程)4mm | C3&C5

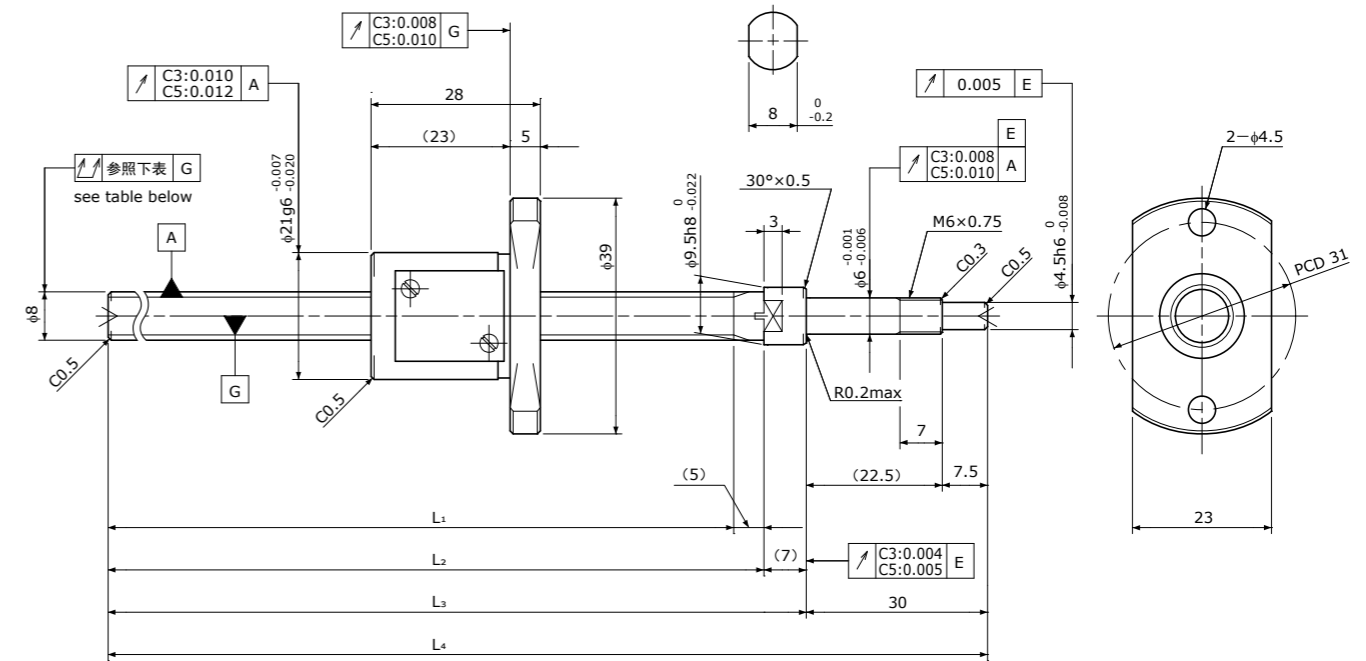

Unit(单位):mm

Ball Screw Specifications 主要技术参数	
Ball size 钢珠直径	$\phi 2.0$
Number of thread 螺纹条数	1
Thread direction 螺纹旋向	Right 右旋
Shaft root dia. 丝杠轴底径	$\phi 6.2$
Number of circuit 循环数	2.7x1
Shaft, Nut material 轴、螺母材质	SCM415H
Surface hardness 螺纹部表面硬度	HRC58~62 (Thread area)
Anti-rust treatment 防锈处理	Anti-rust oil 防锈油

Supported-side end-journal profile 支撑侧轴端加工形状	
A-type	
B-type	
C-type	

L_s : Thread length after end-journal machining. 追加加工后的螺纹部长度
 L_e : Total length after end-journal machining. 追加加工后的总长
 Support-unit Recommendation 推荐的支架组件: Supported-side 支撑侧: MSU-6CS/6GS, Fixed-side 固定侧: MSU-6C/6G
 D-type: Other than the above. 上述以外的形状

Unit(单位):mm

Ball Screw Model 滚珠丝杠型号	Travel 行程	Grade 精度	Shaft length 丝杠轴长度				Lead accuracy 导程精度		Total Run-out 全跳动	Axial play 轴向间隙	Preload Torque 预压扭矩 Nm	Basic Load Rating 基本额定负载 N		
			L ₁	L ₂	L ₃	L ₄	Travel deviation 代表移动量误差 e_p	Variation 波动 V_u				Dynamic 额定动负载 C_a	Static 额定静负载 C_oa	
SG0804-098R140C3	70	C3	98	103	110	140	± 0.008	0.008	0.035	0	Spacer Ball 间隔钢珠 (1:1)	~0.015	1650	2100
SG0804-208R250C3	180	C3	208	213	220	250	± 0.012	0.008	0.050	~0.005		—	2600	4200
SG0804-098R140C5	70	C5	98	103	110	140	± 0.018	0.018	0.050	~0.005	—	2600	4200	
SG0804-208R250C5	180	C5	208	213	220	250	± 0.023	0.018	0.065	~0.005	—	2600	4200	

Note) Please refer to page A206 for order code of end-journal machining. 注) 追加加工的公称型号指定方式请参照A206页。

Standard products in stock SG series
标准库存品 SG系列

SG0802.5 | Shaft dia.(轴径) $\phi 8$ Lead(导程)2.5mm | C5

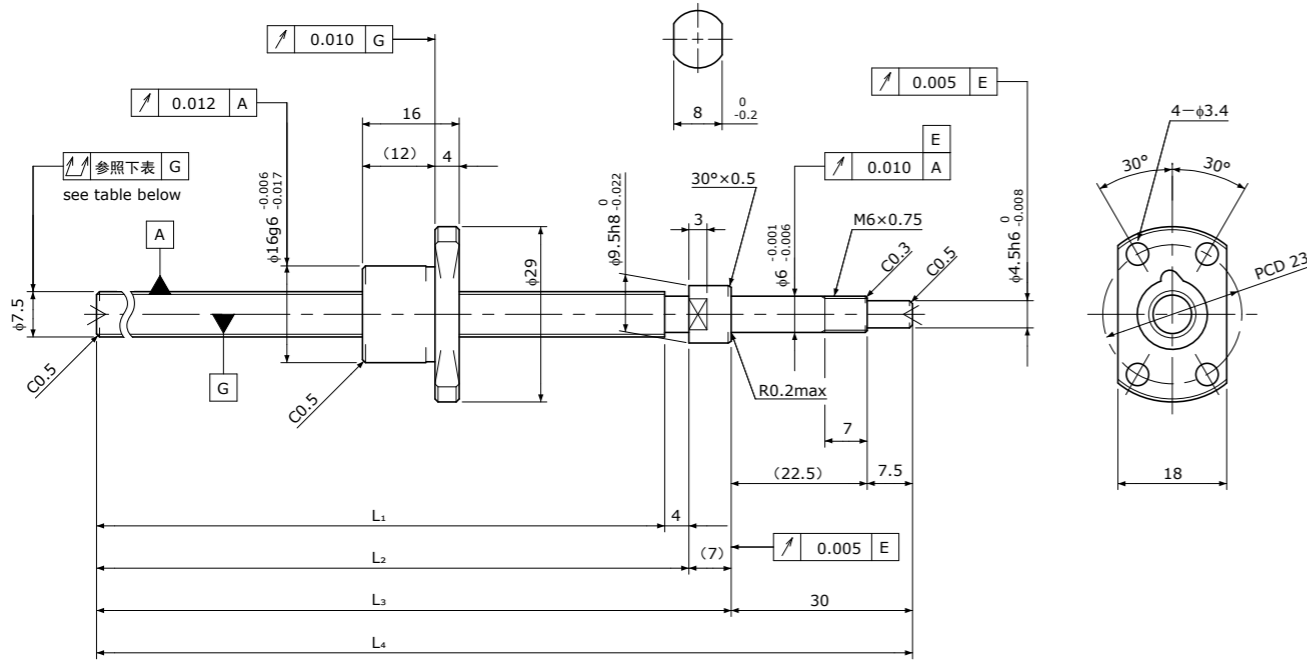

Unit(单位):mm

Ball Screw Specifications 主要技术参数	
Ball size 钢珠直径	$\phi 1.5875$
Number of thread 螺纹条数	1
Thread direction 螺纹旋向	Right 右旋
Shaft root dia. 丝杠轴底径	$\phi 6.3$
Number of circuit 循环数	2.7x1
Shaft, Nut material 轴、螺母材质	SCM415H
Surface hardness 螺纹部表面硬度	HRC58~62 (Thread area)
Anti-rust treatment 防锈处理	Anti-rust oil 防锈油

Supported-side end-journal profile 支撑侧轴端加工形状	
A-type	
B-type	
C-type	

L_s : Thread length after end-journal machining. 追加加工后的螺纹部长度
 L_e : Total length after end-journal machining. 追加加工后的总长
 Support-unit Recommendation 推荐的支架组件: Supported-side 支撑侧: MSU-6CS/6GS, Fixed-side 固定侧: MSU-6C/6G
 D-type: Other than the above. 上述以外的形状

Unit(单位):mm

Ball Screw Model 滚珠丝杠型号	Travel 行程	Grade 精度	Shaft length 丝杠轴长度				Lead accuracy 导程精度		Total Run-out 全跳动	Axial play 轴向间隙	Preload Torque 预压扭矩 Nm	Basic Load Rating 基本额定负载 N	
			L ₁	L ₂	L ₃	L ₄	Travel deviation 代表移动量误差 e_p	Variation 波动 V_u				Dynamic 额定动负载 C_a	Static 额定静负载 C_oa
SG0802.5-129R170C5	110	C5	129	133	140	170	± 0.020	0.018	0.050	~0.005	—	1850	3000
SG0802.5-209R250C5	190	C5	209	213	220	250	± 0.023	0.018	0.065	~0.005	—	1850	3000

Note) Please refer to page A206 for order code of end-journal machining. 注) 追加加工的公称型号指定方式请参照A206页。

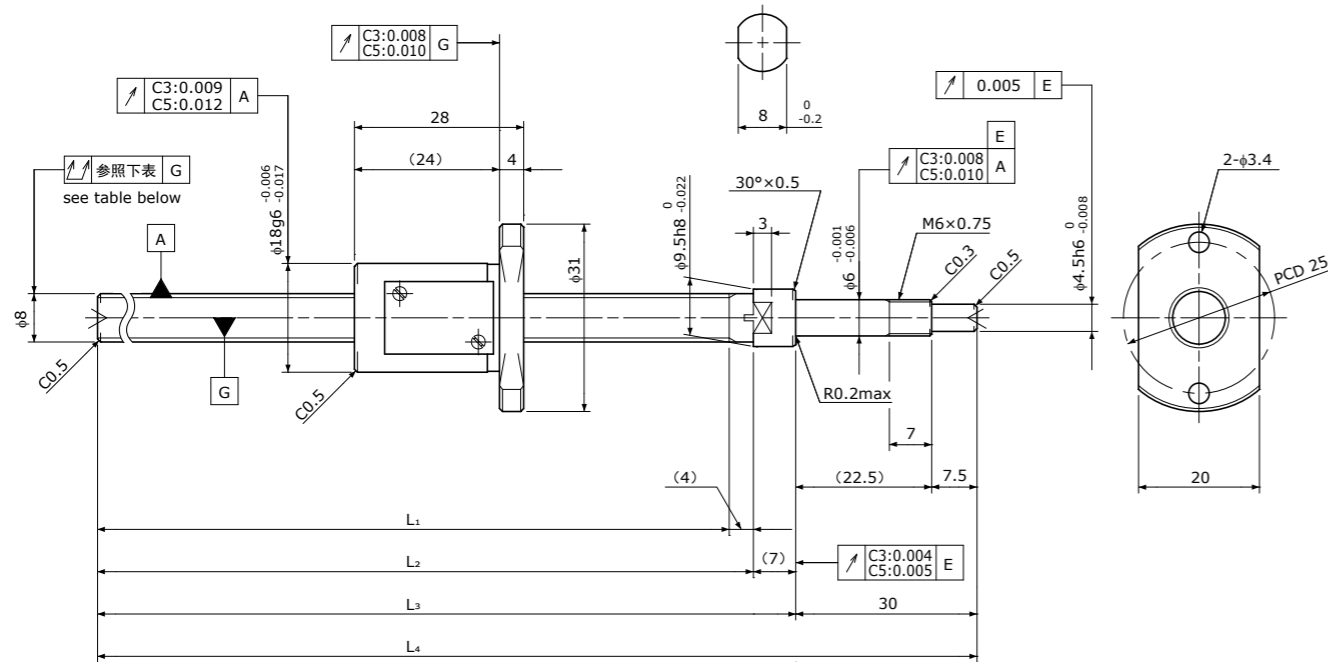
SG0805 | Shaft dia.(轴径) $\phi 8$ Lead(导程)5mm | C3&C5

Unit(单位):mm

Ball Screw Specifications	主要技术参数
Ball size 钢珠直径	$\phi 1.5875$
Number of thread 螺纹条数	1
Thread direction 螺纹旋向	Right 右旋
Shaft root dia. 丝杠轴底径	$\phi 6.6$
Number of circuit 循环数	2.7×1
Shaft, Nut material 轴、螺母材质	SCM415H
Surface hardness 螺纹部表面硬度	HRC58~62 (Thread area)
Anti-rust treatment 防锈处理	Anti-rust oil 防锈油

Supported-side end-journal profile 支撑侧轴端加工形状

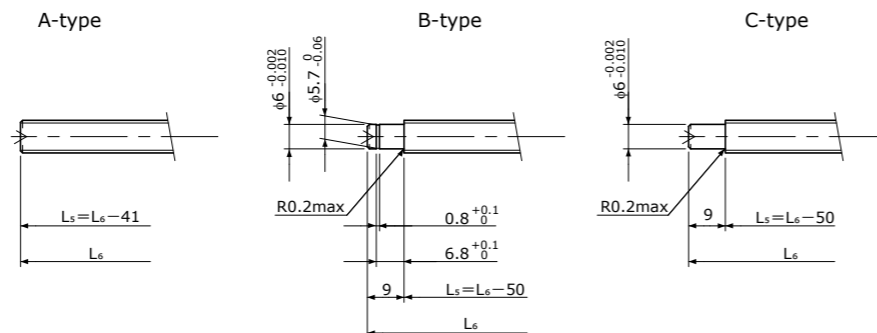

L₅: Thread length after end-journal machining. 追加加工后的螺纹部长度
L₆: Total length after end-journal machining. 追加加工后的总长

Support-unit Recommendation	Supported-side 支撑侧	Fixed-side 固定侧
推荐的支架组件	MSU-6CS/6GS	MSU-6C/6G

D-type: Other than the above. 上述以外的形状

Unit(单位):mm

Ball Screw Model 滚珠丝杠型号	Travel 行程	Grade 精度	Shaft length 丝杠轴长度				Lead accuracy 导程精度		Total Run-out 全跳动	Axial play 轴向间隙	Preload Torque 预压扭矩 Nm	Basic Load Rating 基本额定负载 N	
			L ₁	L ₂	L ₃	L ₄	Travel deviation 代表移动量误差 e _p	Variation 波动 V _u				Dynamic 额定动负载 Ca	Static 额定静负载 Coa
SG0805-099R140C3	70	C3	99	103	110	140	± 0.008	0.008	0.035	0 Spacer Ball 间隔钢珠 (1:1)	~0.015	1150	1500
SG0805-209R250C3	180	C3	209	213	220	250	± 0.012	0.008	0.050				
SG0805-099R140C5	70	C5	99	103	110	140	± 0.018	0.018	0.050	~0.005	—	1850	3000
SG0805-209R250C5	180	C5	209	213	220	250	± 0.023	0.018	0.065				

Note) Please refer to page A206 for order code of end-journal machining. 注) 追加加工的公称型号指定方式请参照A206页。

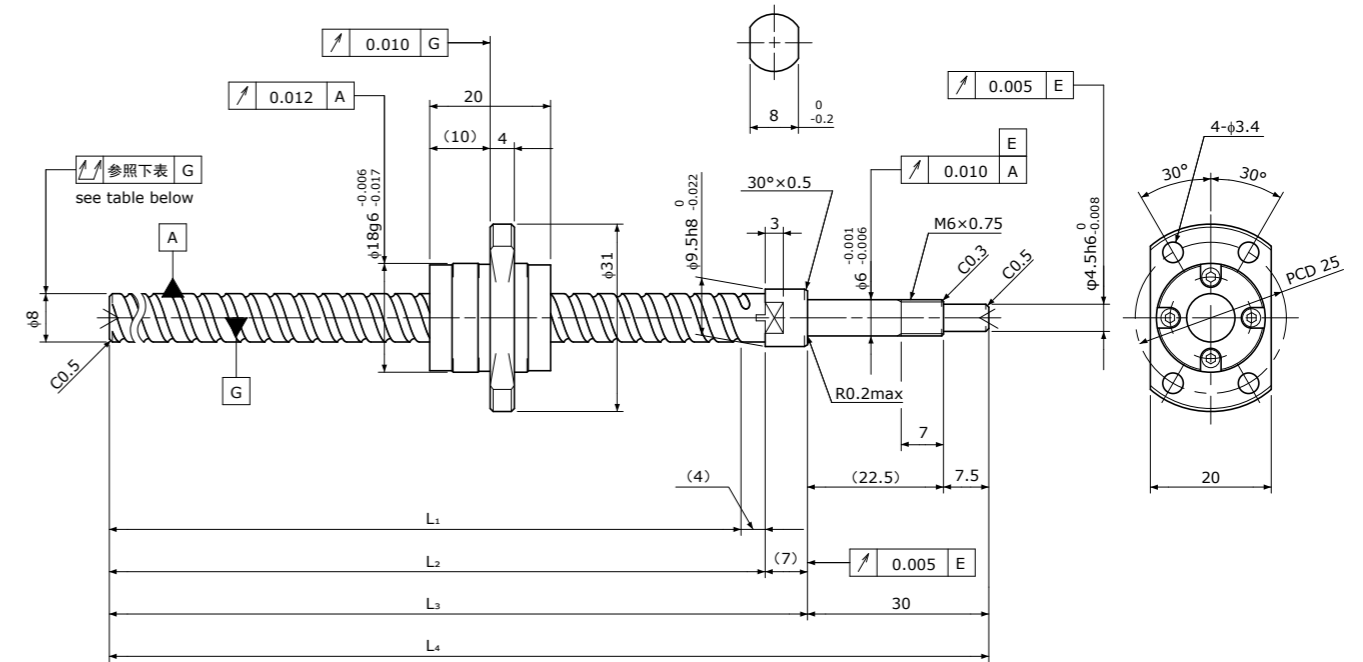
SG0808 | Shaft dia.(轴径) $\phi 8$ Lead(导程)8mm | C5

Unit(单位):mm

Ball Screw Specifications	主要技术参数
Ball size 钢珠直径	$\phi 1.5875$
Number of thread 螺纹条数	2
Thread direction 螺纹旋向	Right 右旋
Shaft root dia. 丝杠轴底径	$\phi 6.7$
Number of circuit 循环数	1.6×2
Shaft, Nut material 轴、螺母材质	SCM415H
Surface hardness 螺纹部表面硬度	HRC58~62 (Thread area)
Anti-rust treatment 防锈处理	Anti-rust oil 防锈油

Supported-side end-journal profile 支撑侧轴端加工形状

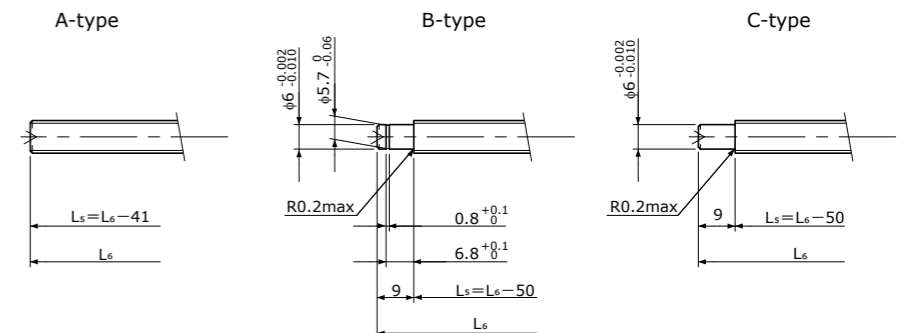

L₅: Thread length after end-journal machining. 追加加工后的螺纹部长度
L₆: Total length after end-journal machining. 追加加工后的总长

Support-unit Recommendation	Supported-side 支撑侧	Fixed-side 固定侧
推荐的支架组件	MSU-6CS/6GS	MSU-6C/6G

D-type: Other than the above. 上述以外的形状

Unit(单位):mm

Ball Screw Model 滚珠丝杠型号	Travel 行程	Grade 精度	Shaft length 丝杠轴长度				Lead accuracy 导程精度		Total Run-out 全跳动	Axial play 轴向间隙	Preload Torque 预压扭矩 Nm	Basic Load Rating 基本额定负载 N	
			L ₁	L ₂	L ₃	L ₄	Travel deviation 代表移动量误差 e _p	Variation 波动 V _u				Dynamic 额定动负载 Ca	Static 额定静负载 Coa
SG0808-099R140C5	75	C5	99	103	110	140	± 0.018	0.018	0.050	~0.005	—	2200	3800
SG0808-209R250C5	185	C5	209	213	220	250	± 0.023	0.018	0.065				

Note) Please refer to page A206 for order code of end-journal machining. 注) 追加加工的公称型号指定方式请参照A206页。

SG0812

Shaft dia.(轴径) $\phi 8$ Lead(导程)12mm

C5

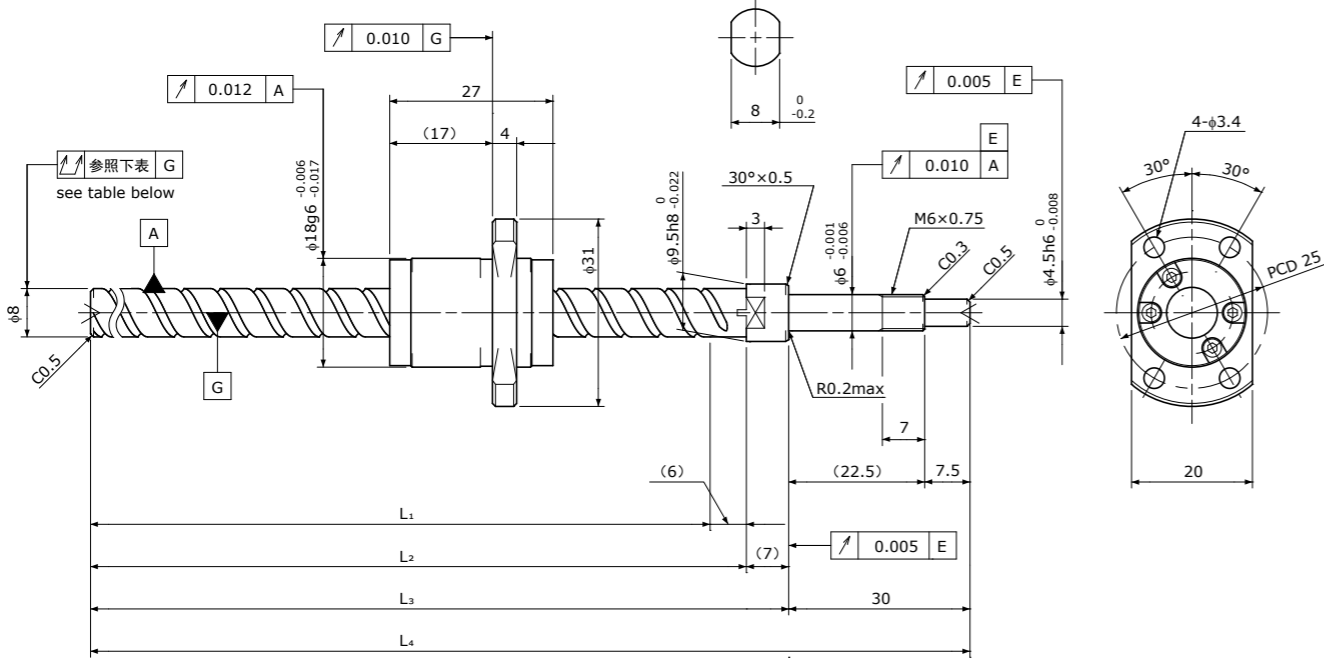

Unit(单位):mm

Ball Screw Specifications 主要技术参数	
Ball size 钢珠直径	$\phi 1.5875$
Number of thread 螺纹条数	2
Thread direction 螺纹旋向	Right 右旋
Shaft root dia. 丝杠轴底径	$\phi 6.7$
Number of circuit 循环数	1.6 X 2
Shaft, Nut material 轴、螺母材质	SCM415H
Surface hardness 螺纹部表面硬度	HRC58~62 (Thread area)
Anti-rust treatment 防锈处理	Anti-rust oil 防锈油

Supported-side end-journal profile 支撑侧轴端加工形状

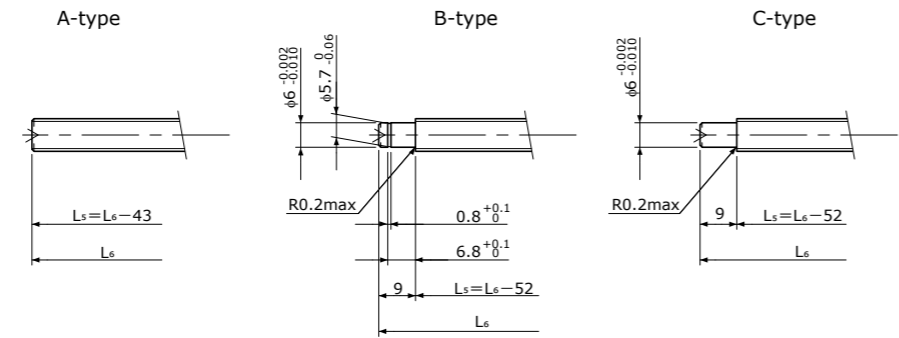

L_5 : Thread length after end-journal machining. 追加加工后的螺纹部长度
 L_6 : Total length after end-journal machining. 追加加工后的总长

Support-unit Recommendation 推荐的支架组件	Supported-side 支撑侧	Fixed-side 固定侧
	MSU-6CS/6GS	MSU-6C/6G

D-type : Other than the above. 上述以外的形状

Unit(单位):mm

Ball Screw Model 滚珠丝杠型号	Travel 行程	Grade 精度	Shaft length 丝杠轴长度				Lead accuracy 导程精度		Total Run-out 全跳动	Axial play 轴向间隙	Preload Torque 预压扭矩 Nm	Basic Load Rating 基本额定负载 N	
			L_1	L_2	L_3	L_4	Travel deviation 代表移动量误差 e_p	Variation 波动 V_u				Dynamic 额定动负载 C_a	Static 额定静负载 C_oa
SG0812-097R140C5	70	C5	97	103	110	140	± 0.018	0.018	0.050	~0.005	—	2200	4000
SG0812-207R250C5	180	C5	207	213	220	250	± 0.023	0.018	0.065				

Note) Please refer to page A206 for order code of end-journal machining. 注) 追加加工的公称型号指定方式请参照A206页。

SG1001

Shaft dia.(轴径) $\phi 10$ Lead(导程)1mm

C3&C5

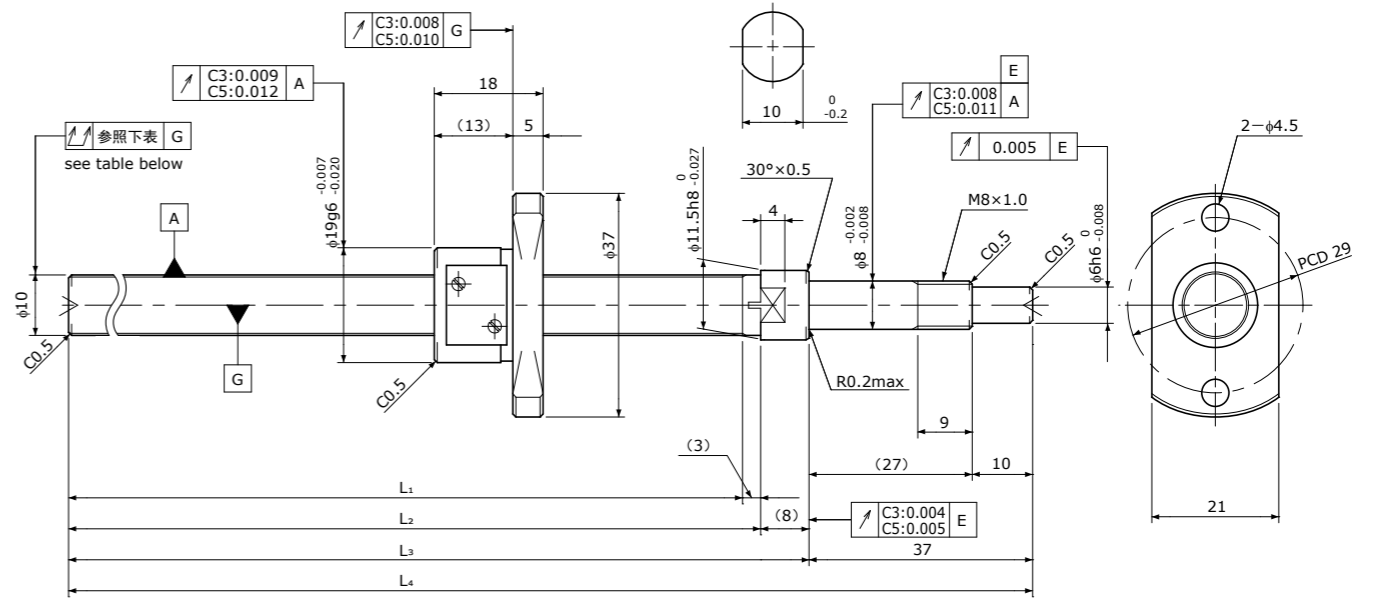

Unit(单位):mm

Ball Screw Specifications 主要技术参数	
Ball size 钢珠直径	$\phi 0.8$
Number of thread 螺纹条数	1
Thread direction 螺纹旋向	Right 右旋
Shaft root dia. 丝杠轴底径	$\phi 9.3$
Number of circuit 循环数	3.7 X 1
Shaft, Nut material 轴、螺母材质	SCM415H
Surface hardness 螺纹部表面硬度	HRC58~62 (Thread area)
Anti-rust treatment 防锈处理	Anti-rust oil 防锈油

Supported-side end-journal profile 支撑侧轴端加工形状

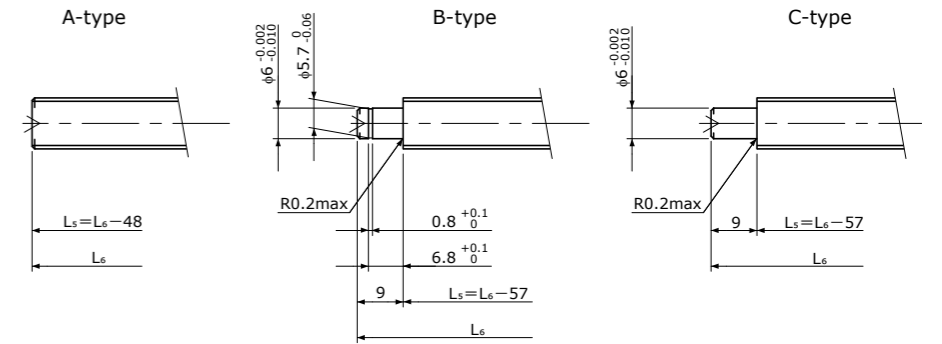

L_5 : Thread length after end-journal machining. 追加加工后的螺纹部长度
 L_6 : Total length after end-journal machining. 追加加工后的总长

Support-unit Recommendation 推荐的支架组件	Supported-side 支撑侧	Fixed-side 固定侧
	MSU-8CS/8GS	MSU-8C/8G

D-type : Other than the above. 上述以外的形状

Unit(单位):mm

Ball Screw Model 滚珠丝杠型号	Travel 行程	Grade 精度	Shaft length 丝杠轴长度				Lead accuracy 导程精度		Total Run-out 全跳动	Axial play 轴向间隙	Preload Torque 预压扭矩 Nm	Basic Load Rating 基本额定负载 N	
			L_1	L_2	L_3	L_4	Travel deviation 代表移动量误差 e_p	Variation 波动 V_u				Dynamic 额定动负载 C_a	Static 额定静负载 C_oa
SG1001-112R160C3	90	C3	112	115	123	160	± 0.010	0.008	0.035	0 Spacer Ball 间隔钢珠 (1:1)	~0.020	530	1000
SG1001-162R210C3	140	C3	162	165	173	210	± 0.010	0.008	0.040				
SG1001-212R260C3	190	C3	212	215	223	260	± 0.012	0.008	0.040				
SG1001-262R310C3	240	C3	262	265	273	310	± 0.012	0.008	0.040	~0.005	—	840	2000
SG1001-112R160C5	90	C5	112	115	123	160	± 0.020	0.018	0.040				
SG1001-162R210C5	140	C5	162	165	173	210	± 0.020	0.018	0.055				
SG1001-212R260C5	190	C5	212	215	223	260	± 0.023	0.018	0.055				
SG1001-262R310C5	240	C5	262	265	273	310	± 0.023	0.018	0.055				

Note) Please refer to page A206 for order code of end-journal machining. 注) 追加加工的公称型号指定方式请参照A206页。

Standard products in stock SG series
标准库存品 SG系列

SG1002 | Shaft dia.(轴径) $\phi 10$ Lead(导程)2mm | C3&C5

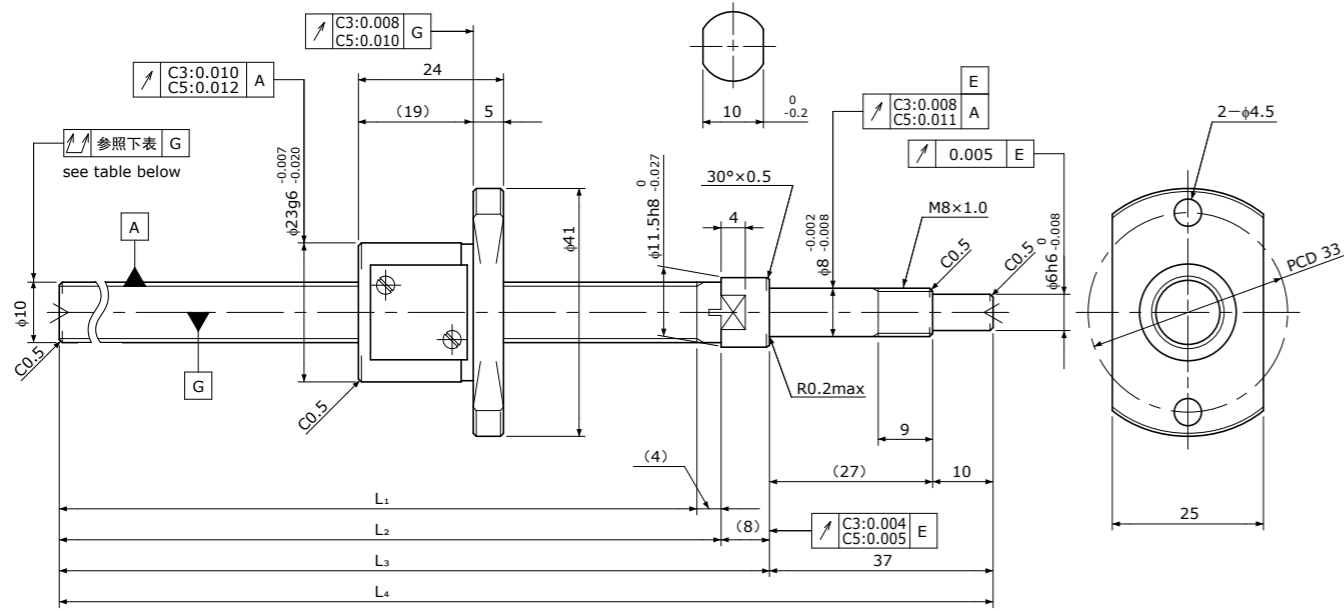

Unit(单位):mm

Ball Screw Specifications 主要技术参数	
Ball size 钢珠直径	$\phi 1.5875$
Number of thread 螺纹条数	1
Thread direction 螺纹旋向	Right 右旋
Shaft root dia. 丝杠轴底径	$\phi 8.6$
Number of circuit 循环数	3.7×1
Shaft, Nut material 轴、螺母材质	SCM415H
Surface hardness 螺纹部表面硬度	HRC58~62 (Thread area)
Anti-rust treatment 防锈处理	Anti-rust oil 防锈油

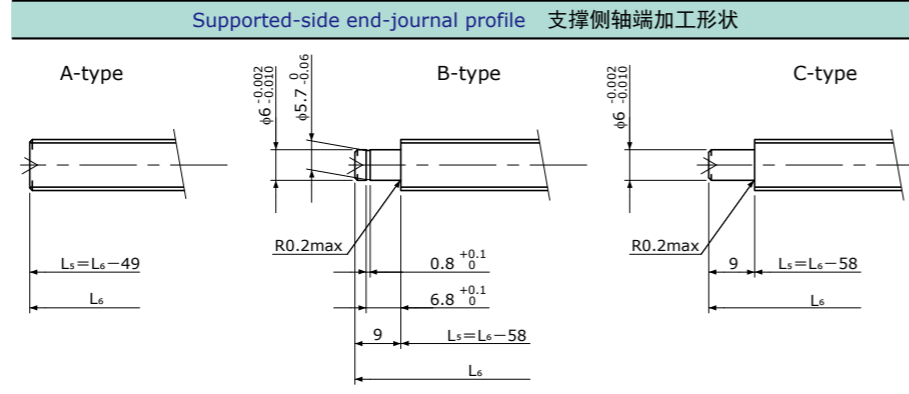

Ls: Thread length after end-journal machining. 追加加工后的螺纹部长度
L6: Total length after end-journal machining. 追加加工后的总长

Support-unit Recommendation 推荐的支架组件	Supported-side 支撑侧	Fixed-side 固定侧
	MSU-8CS/8GS	MSU-8C/8G

D-type: Other than the above. 上述以外的形状

Unit(单位):mm

Ball Screw Model 滚珠丝杠型号	Travel 行程	Grade 精度	Shaft length 丝杠轴长度				Lead accuracy 导程精度		Total Run-out 全跳动	Axial play 轴向间隙	Preload Torque 预压扭矩 Nm	Basic Load Rating 基本额定负载 N	
			L1	L2	L3	L4	Travel deviation 代表移动量误差 e_p	Variation 波动 V_u				Dynamic 额定动负载 C_a	Static 额定静负载 C_oa
SG1002-111R160C3	85	C3	111	115	123	160	± 0.010	0.008	0.035	0 Spacer Ball 间隔钢珠 (1:1)	0.006~ 0.030	1750	2700
SG1002-161R210C3	135	C3	161	165	173	210	± 0.010	0.008	0.040				
SG1002-211R260C3	185	C3	211	215	223	260	± 0.012	0.008	0.040				
SG1002-261R310C3	235	C3	261	265	273	310	± 0.012	0.008	0.040	~0.005	—	2700	5300
SG1002-111R160C5	85	C5	111	115	123	160	± 0.020	0.018	0.040				
SG1002-161R210C5	135	C5	161	165	173	210	± 0.020	0.018	0.055				
SG1002-211R260C5	185	C5	211	215	223	260	± 0.023	0.018	0.055				
SG1002-261R310C5	235	C5	261	265	273	310	± 0.023	0.018	0.055				

Note) Please refer to page A206 for order code of end-journal machining. 注) 追加加工的公称型号指定方式请参照A206页。

Standard products in stock SG series
标准库存品 SG系列

SG1004 | Shaft dia.(轴径) $\phi 10$ Lead(导程)4mm | C3&C5

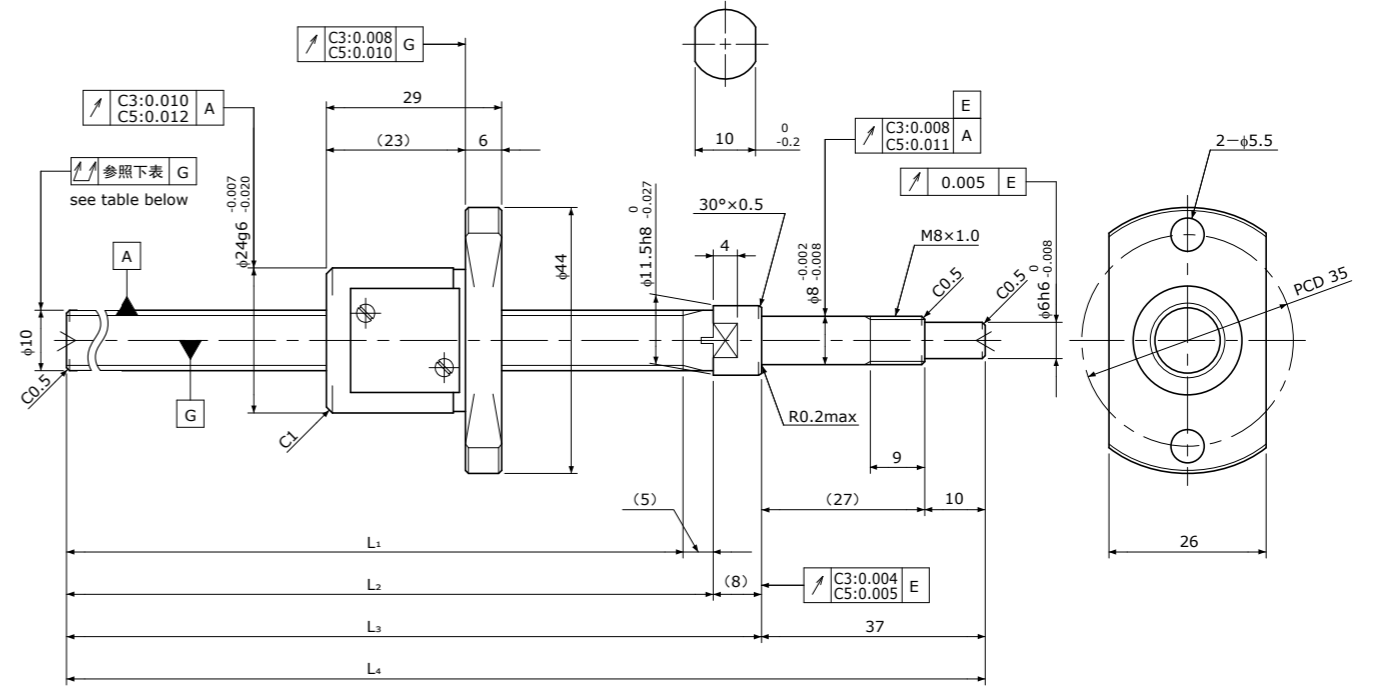

Unit(单位):mm

Ball Screw Specifications 主要技术参数	
Ball size 钢珠直径	$\phi 2.0$
Number of thread 螺纹条数	1
Thread direction 螺纹旋向	Right 右旋
Shaft root dia. 丝杠轴底径	$\phi 8.2$
Number of circuit 循环数	2.7×1
Shaft, Nut material 轴、螺母材质	SCM415H
Surface hardness 螺纹部表面硬度	HRC58~62 (Thread area)
Anti-rust treatment 防锈处理	Anti-rust oil 防锈油

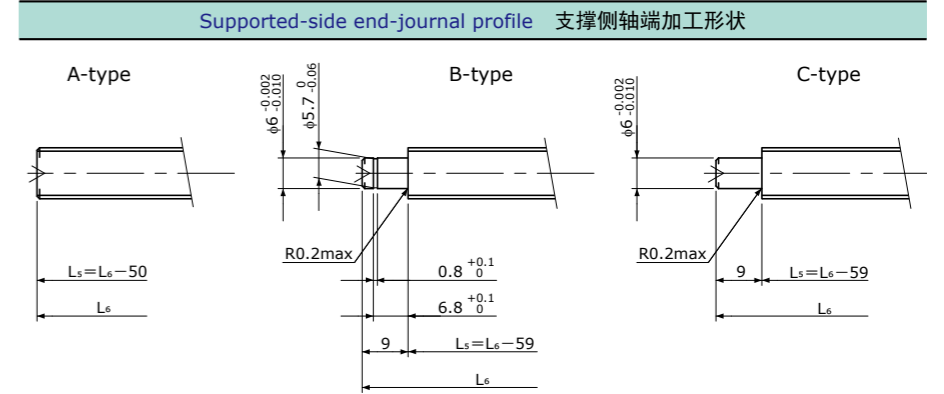

Ls: Thread length after end-journal machining. 追加加工后的螺纹部长度
L6: Total length after end-journal machining. 追加加工后的总长

Support-unit Recommendation 推荐的支架组件	Supported-side 支撑侧	Fixed-side 固定侧
	MSU-8CS/8GS	MSU-8C/8G

D-type: Other than the above. 上述以外的形状

Unit(单位):mm

Ball Screw Model 滚珠丝杠型号	Travel 行程	Grade 精度	Shaft length 丝杠轴长度				Lead accuracy 导程精度		Total Run-out 全跳动	Axial play 轴向间隙	Preload Torque 预压扭矩 Nm	Basic Load Rating 基本额定负载 N	
			L1	L2	L3	L4	Travel deviation 代表移动量误差 e_p	Variation 波动 V_u				Dynamic 额定动负载 C_a	Static 额定静负载 C_oa
SG1004-110R160C3	80	C3	110	115	123	160	± 0.010	0.008	0.035	0 Spacer Ball 间隔钢珠 (1:1)	0.005~ 0.040	1800	2600
SG1004-260R310C3	230	C3	260	265	273	310	± 0.012	0.008	0.040				
SG1004-110R160C5	80	C5	110	115	123	160	± 0.020	0.018	0.040	~0.005	—	3000	5200
SG1004-260R310C5	230	C5	260	265	273	310	± 0.023	0.018	0.055				

Note) Please refer to page A206 for order code of end-journal machining. 注) 追加加工的公称型号指定方式请参照A206页。

SG1005 | Shaft dia.(轴径) $\phi 10$ Lead(导程)5mm | C3&C5

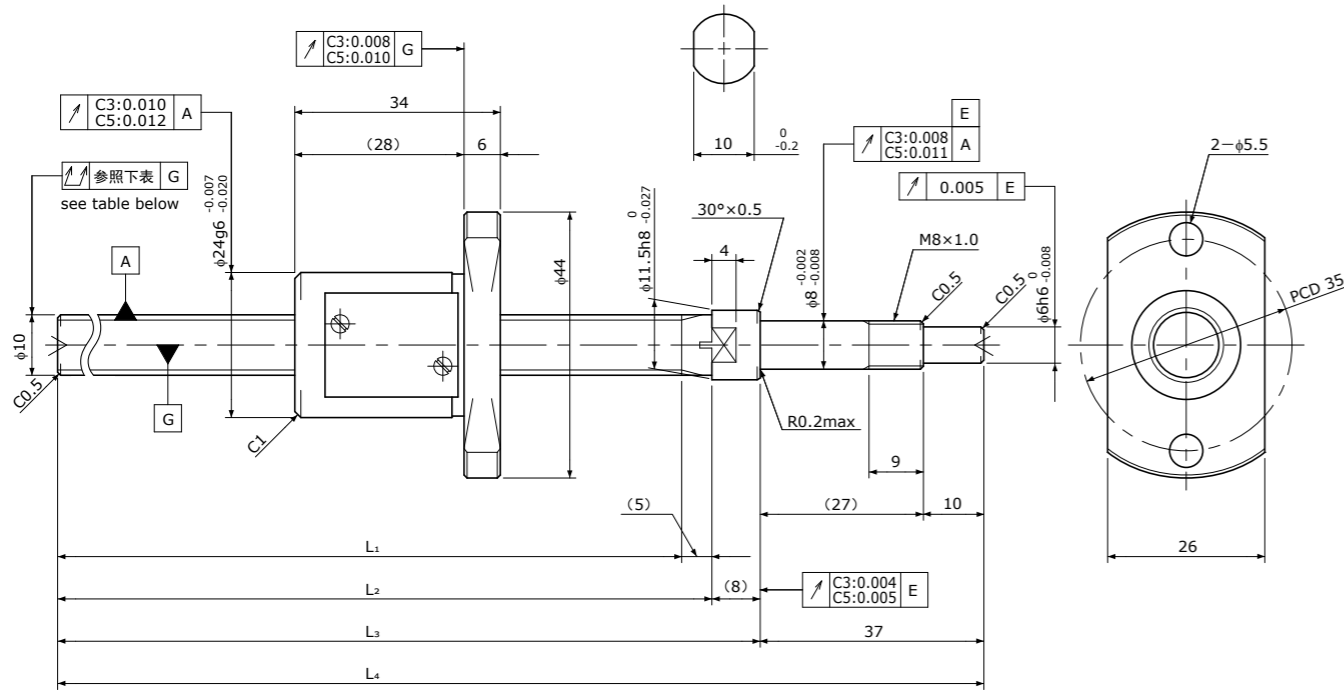

Unit(单位):mm

Ball Screw Specifications 主要技术参数	
Ball size 钢珠直径	$\phi 2.0$
Number of thread 螺纹条数	1
Thread direction 螺纹旋向	Right 右旋
Shaft root dia. 丝杠轴底径	$\phi 8.2$
Number of circuit 循环数	2.7 × 1
Shaft, Nut material 轴、螺母材质	SCM415H
Surface hardness 螺纹部表面硬度	HRC58~62 (Thread area)
Anti-rust treatment 防锈处理	Anti-rust oil 防锈油

Supported-side end-journal profile 支撑侧轴端加工形状

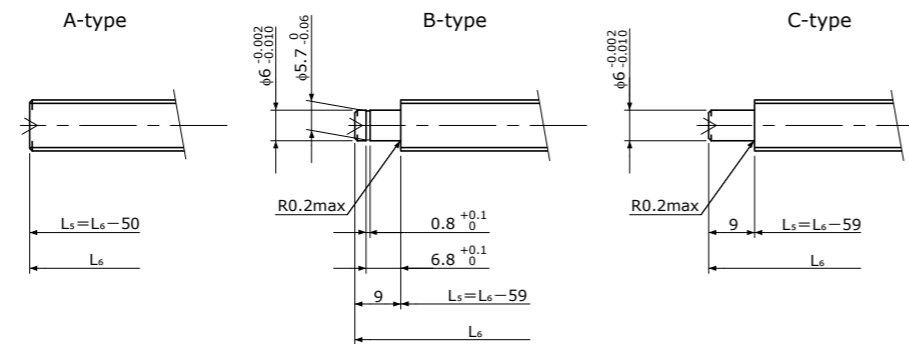

L₅: Thread length after end-journal machining. 追加加工后的螺纹部长度
L₆: Total length after end-journal machining. 追加加工后的总长

Support-unit Recommendation 推荐的支架组件	Supported-side 支撑侧	Fixed-side 固定侧
	MSU-8CS/8GS	MSU-8C/8G

D-type: Other than the above. 上述以外的形状

Unit(单位):mm

Ball Screw Model 滚珠丝杠型号	Travel 行程	Grade 精度	Shaft length 丝杠轴长度				Lead accuracy 导程精度		Total Run-out 全跳动	Axial play 轴向间隙	Preload Torque 预压扭矩 Nm	Basic Load Rating 基本额定负载 N	
			L ₁	L ₂	L ₃	L ₄	Travel deviation 代表移动量误差 e _p	Variation 波动 V _u				Dynamic 额定动负载 Ca	Static 额定静负载 Coa
SG1005-110R160C3	75	C3	110	115	123	160	±0.010	0.008	0.035	0 Spacer Ball 间隔钢珠 (1:1)	0.005~ 0.040	1800	2600
SG1005-260R310C3	225	C3	260	265	273	310	±0.012	0.008	0.040				
SG1005-110R160C5	75	C5	110	115	123	160	±0.020	0.018	0.040	~0.005	—	3000	5200
SG1005-260R310C5	225	C5	260	265	273	310	±0.023	0.018	0.055				

Note) Please refer to page A206 for order code of end-journal machining. 注) 追加加工的公称型号指定方式请参照A206页。

SG1010 | Shaft dia.(轴径) $\phi 10$ Lead(导程)10mm | C5

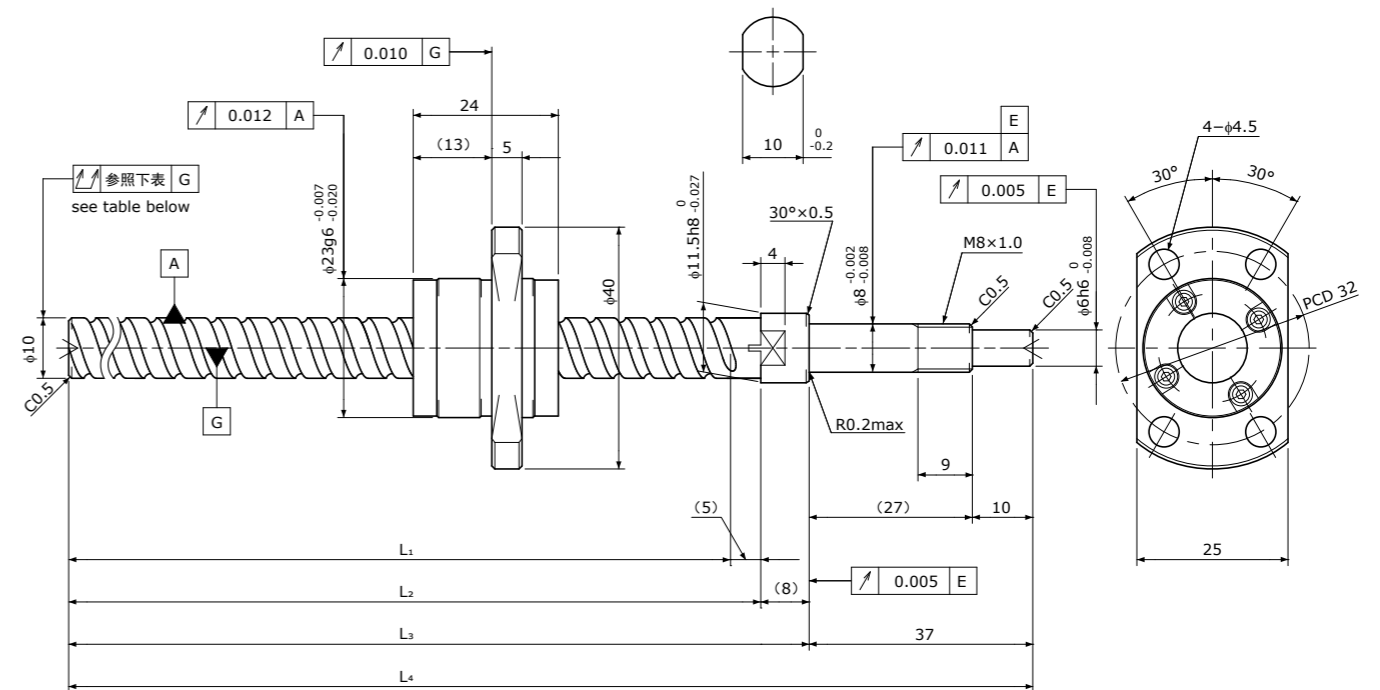

Unit(单位):mm

Ball Screw Specifications 主要技术参数	
Ball size 钢珠直径	$\phi 2.0$
Number of thread 螺纹条数	2
Thread direction 螺纹旋向	Right 右旋
Shaft root dia. 丝杠轴底径	$\phi 8.4$
Number of circuit 循环数	1.6 × 2
Shaft, Nut material 轴、螺母材质	SCM415H
Surface hardness 螺纹部表面硬度	HRC58~62 (Thread area)
Anti-rust treatment 防锈处理	Anti-rust oil 防锈油

Supported-side end-journal profile 支撑侧轴端加工形状

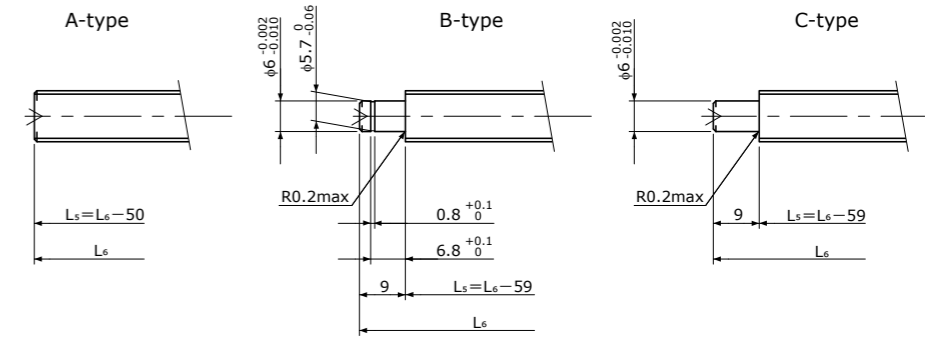

L₅: Thread length after end-journal machining. 追加加工后的螺纹部长度
L₆: Total length after end-journal machining. 追加加工后的总长

Support-unit Recommendation 推荐的支架组件	Supported-side 支撑侧	Fixed-side 固定侧
	MSU-8CS/8GS	MSU-8C/8G

D-type: Other than the above. 上述以外的形状

Unit(单位):mm

Ball Screw Model 滚珠丝杠型号	Travel 行程	Grade 精度	Shaft length 丝杠轴长度				Lead accuracy 导程精度		Total Run-out 全跳动	Axial play 轴向间隙	Preload Torque 预压扭矩 Nm	Basic Load Rating 基本额定负载 N	
			L ₁	L ₂	L ₃	L ₄	Travel deviation 代表移动量误差 e _p	Variation 波动 V _u				Dynamic 额定动负载 Ca	Static 额定静负载 Coa
SG1010-110R160C5	85	C5	110	115	123	160	±0.020	0.018	0.040	~0.005	—	3300	5900
SG1010-260R310C5	235	C5	260	265	273	310	±0.023	0.018	0.055				

Note) Please refer to page A206 for order code of end-journal machining. 注) 追加加工的公称型号指定方式请参照A206页。

Standard products in stock SG series
标准库存品 SG系列

SG1015

Shaft dia.(轴径) $\phi 10$ Lead(导程)15mm

C5

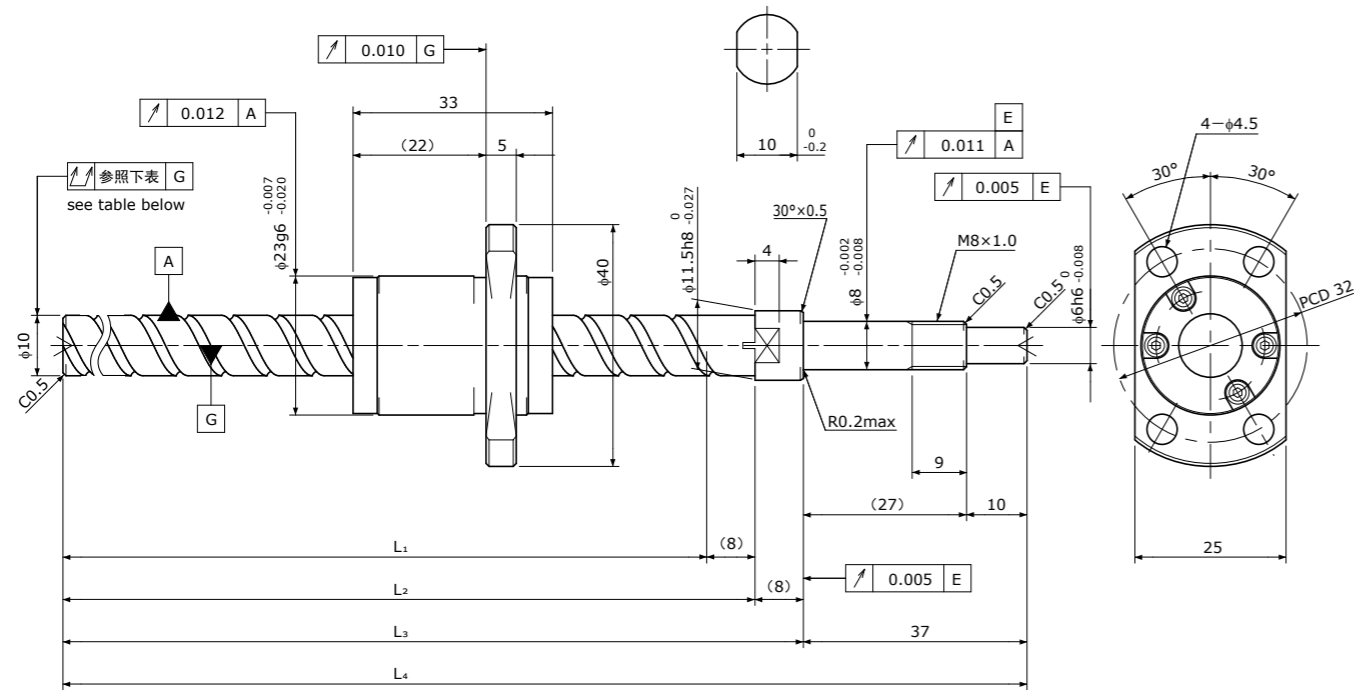

Unit(单位):mm

Ball Screw Specifications 主要技术参数	
Ball size 钢珠直径	$\phi 2.0$
Number of thread 螺纹条数	2
Thread direction 螺纹旋向	Right 右旋
Shaft root dia. 丝杠轴底径	$\phi 8.4$
Number of circuit 循环数	1.6 × 2
Shaft, Nut material 轴、螺母材质	SCM415H
Surface hardness 螺纹部表面硬度	HRC58~62 (Thread area)
Anti-rust treatment 防锈处理	Anti-rust oil 防锈油

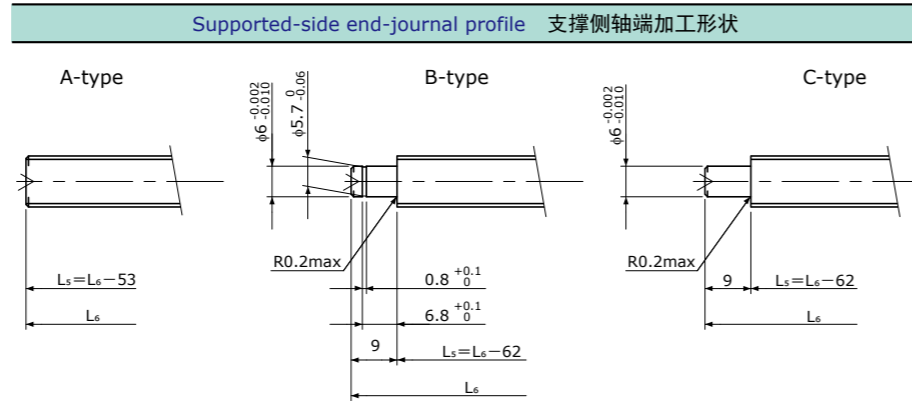

L5: Thread length after end-journal machining. 追加加工后的螺纹部长度
L6: Total length after end-journal machining. 追加加工后的总长

Support-unit Recommendation 推荐的支架组件	
Supported-side 支撑侧	MSU-8CS/8GS
Fixed-side 固定侧	MSU-8C/8G

D-type: Other than the above. 上述以外的形状

Unit(单位):mm

Ball Screw Model 滚珠丝杠型号	Travel 行程	Grade 精度	Shaft length 丝杠轴长度				Lead accuracy 导程精度		Total Run-out 全跳动	Axial play 轴向间隙	Preload Torque 预压扭矩 Nm	Basic Load Rating 基本额定负载 N	
			L1	L2	L3	L4	Travel deviation 代表移动量误差 e _p	Variation 波动 V _u				Dynamic 额定动负载 Ca	Static 额定静负载 Coa
SG1015-107R160C5	70	C5	107	115	123	160	±0.020	0.018	0.040	~0.005	—	3300	6400
SG1015-257R310C5	220	C5	257	265	273	310	±0.023	0.018	0.055				

Note) Please refer to page A206 for order code of end-journal machining. 注) 追加加工的公称型号指定方式请参照A206页。

Standard products in stock SG series
标准库存品 SG系列

SG1202

Shaft dia.(轴径) $\phi 12$ Lead(导程)2mm

C3&C5

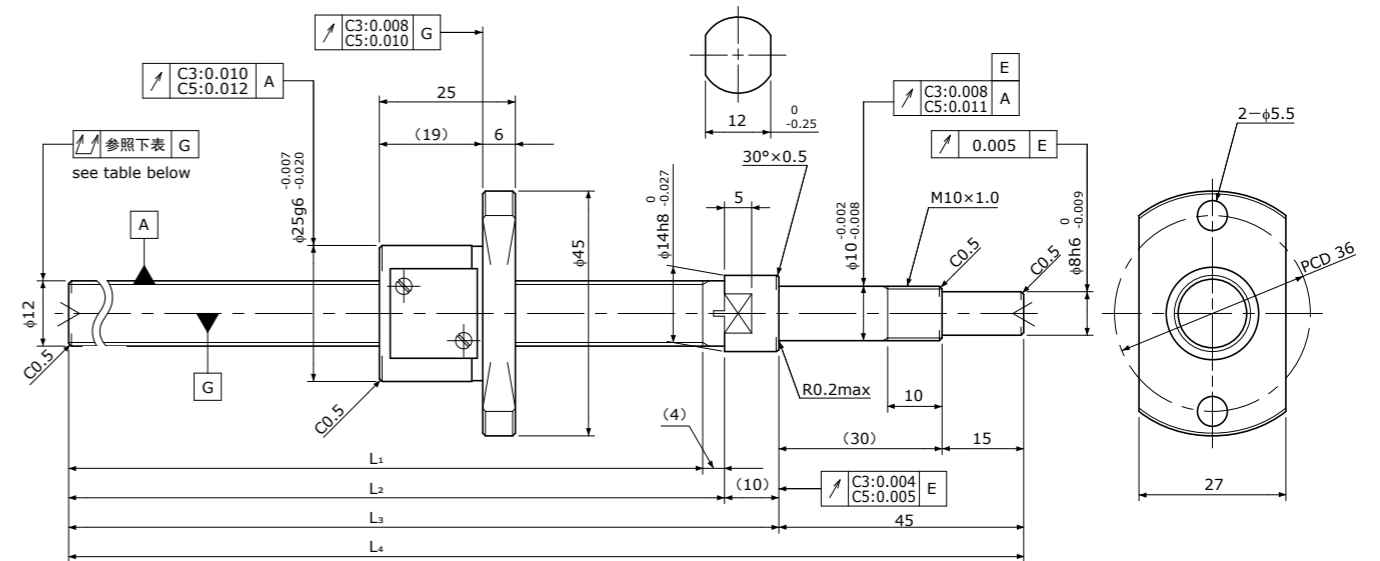

Unit(单位):mm

Ball Screw Specifications 主要技术参数	
Ball size 钢珠直径	$\phi 1.5875$
Number of thread 螺纹条数	1
Thread direction 螺纹旋向	Right 右旋
Shaft root dia. 丝杠轴底径	$\phi 10.6$
Number of circuit 循环数	3.7 × 1
Shaft, Nut material 轴、螺母材质	SCM415H
Surface hardness 螺纹部表面硬度	HRC58~62 (Thread area)
Anti-rust treatment 防锈处理	Anti-rust oil 防锈油

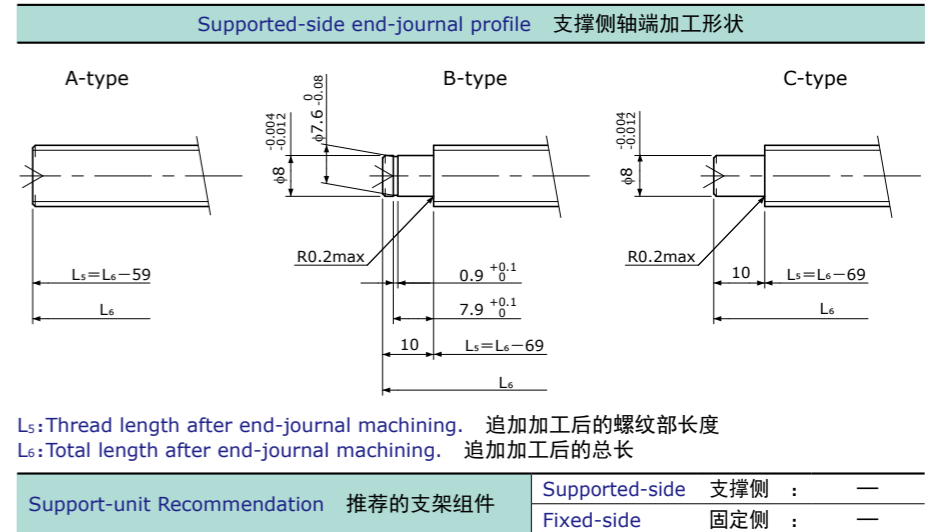

L5: Thread length after end-journal machining. 追加加工后的螺纹部长度
L6: Total length after end-journal machining. 追加加工后的总长

Support-unit Recommendation 推荐的支架组件	
Supported-side 支撑侧	—
Fixed-side 固定侧	—

D-type: Other than the above. 上述以外的形状

Unit(单位):mm

Ball Screw Model 滚珠丝杠型号	Travel 行程	Grade 精度	Shaft length 丝杠轴长度				Lead accuracy 导程精度		Total Run-out 全跳动	Axial play 轴向间隙	Preload Torque 预压扭矩 Nm	Basic Load Rating 基本额定负载 N	
			L1	L2	L3	L4	Travel deviation 代表移动量误差 e _p	Variation 波动 V _u				Dynamic 额定动负载 Ca	Static 额定静负载 Coa
SG1202-141R200C3	115	C3	141	145	155	200	±0.010	0.008	0.035	0 Spacer Ball 间隔钢珠 (1:1)	0.008~ 0.040	1900	3200
SG1202-191R250C3	165	C3	191	195	205	250	±0.010	0.008	0.040				
SG1202-241R300C3	215	C3	241	245	255	300	±0.012	0.008	0.040				
SG1202-291R350C3	265	C3	291	295	305	350	±0.012	0.008	0.050				
SG1202-341R400C3	315	C3	341	345	355	400	±0.013	0.010	0.050				
SG1202-141R200C5	115	C5	141	145	155	200	±0.020	0.018	0.040	~0.005	—	3000	6400
SG1202-191R250C5	165	C5	191	195	205	250	±0.020	0.018	0.055				
SG1202-241R300C5	215	C5	241	245	255	300	±0.023	0.018	0.055				
SG1202-291R350C5	265	C5	291	295	305	350	±0.023	0.018	0.065				
SG1202-341R400C5	315	C5	341	345	355	400	±0.025	0.020	0.065				

Note) Please refer to page A206 for order code of end-journal machining. 注) 追加加工的公称型号指定方式请参照A206页。

Standard products in stock SG series
标准库存品 SG系列

SG1210

Shaft dia.(轴径)φ12 Lead(导程)10mm

C5

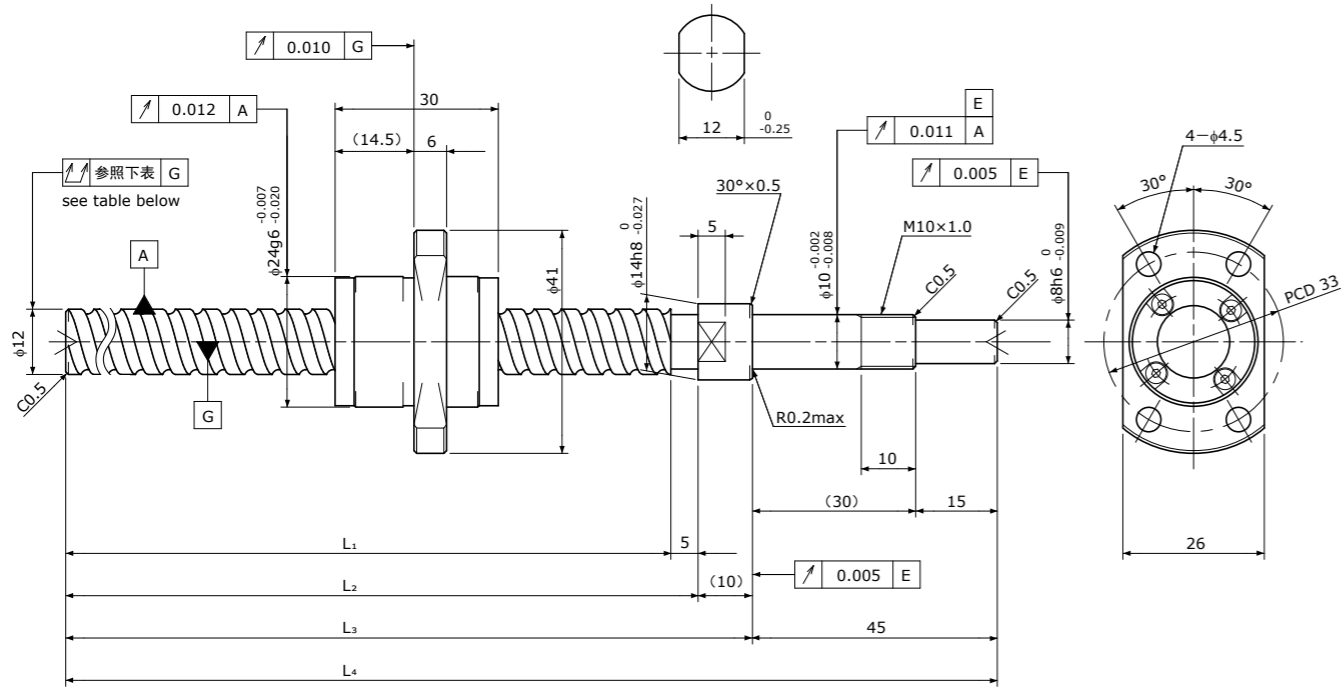

Unit(单位):mm

Ball Screw Specifications 主要技术参数	
Ball size 钢珠直径	φ2.381
Number of thread 螺纹条数	2
Thread direction 螺纹旋向	Right 右旋
Shaft root dia. 丝杠轴底径	φ10.2
Number of circuit 循环数	1.7×2
Shaft, Nut material 轴、螺母材质	SCM415H
Surface hardness 螺纹部表面硬度	HRC58~62 (Thread area)
Anti-rust treatment 防锈处理	Anti-rust oil 防锈油

Supported-side end-journal profile 支撑侧轴端加工形状

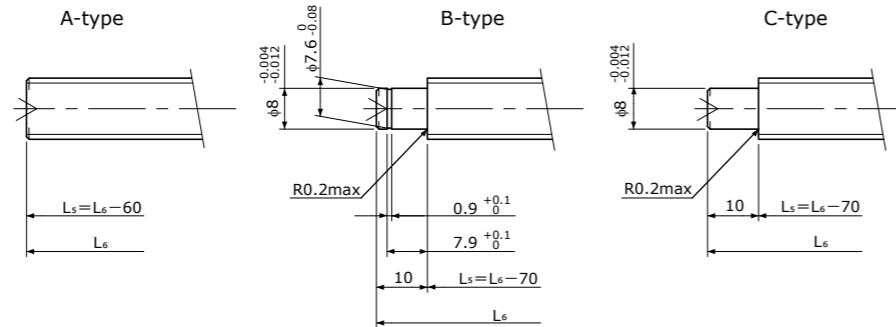

L5: Thread length after end-journal machining. 追加加工后的螺纹部长度
L6: Total length after end-journal machining. 追加加工后的总长

Support-unit Recommendation 推荐的支架组件	
Supported-side 支撑侧	—
Fixed-side 固定侧	—

D-type: Other than the above. 上述以外的形状

Unit(单位):mm

Ball Screw Model 滚珠丝杠型号	Travel 行程	Grade 精度	Shaft length 丝杠轴长度				Lead accuracy 导程精度		Total Run-out 全跳动	Axial play 轴向间隙	Preload Torque 预压扭矩 Nm	Basic Load Rating 基本额定负载 N	
			L1	L2	L3	L4	Travel deviation 代表移动量误差 e _p	Variation 波动 V _u				Dynamic 额定动负载 Ca	Static 额定静负载 Coa
SG1210-240R300C5	210	C5	240	245	255	300	±0.023	0.018	0.055	~0.005	—	5100	9800
SG1210-340R400C5	310	C5	340	345	355	400	±0.025	0.020	0.065				

Note) Please refer to page A206 for order code of end-journal machining. 注) 追加加工的公称型号指定方式请参照A206页。

Standard products in stock SG series
标准库存品 SG系列

SG1402

Shaft dia.(轴径)φ14 Lead(导程)2mm

C3&C5

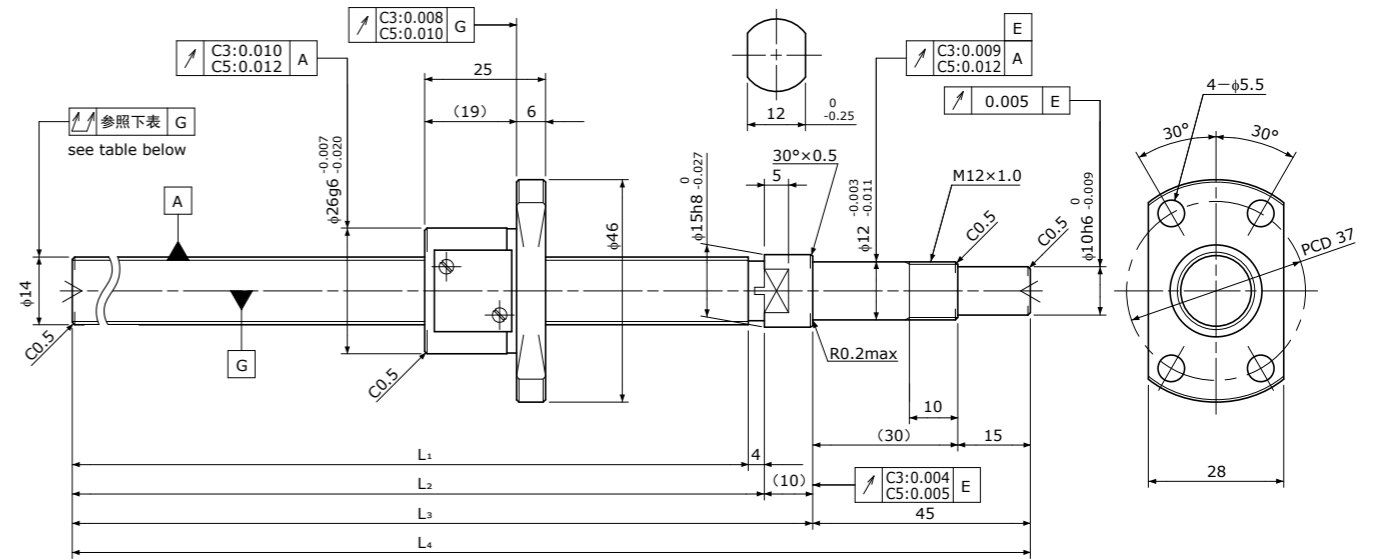

Unit(单位):mm

Ball Screw Specifications 主要技术参数	
Ball size 钢珠直径	φ1.5875
Number of thread 螺纹条数	1
Thread direction 螺纹旋向	Right 右旋
Shaft root dia. 丝杠轴底径	φ12.6
Number of circuit 循环数	3.7×1
Shaft, Nut material 轴、螺母材质	SCM415H
Surface hardness 螺纹部表面硬度	HRC58~62 (Thread area)
Anti-rust treatment 防锈处理	Anti-rust oil 防锈油

Supported-side end-journal profile 支撑侧轴端加工形状

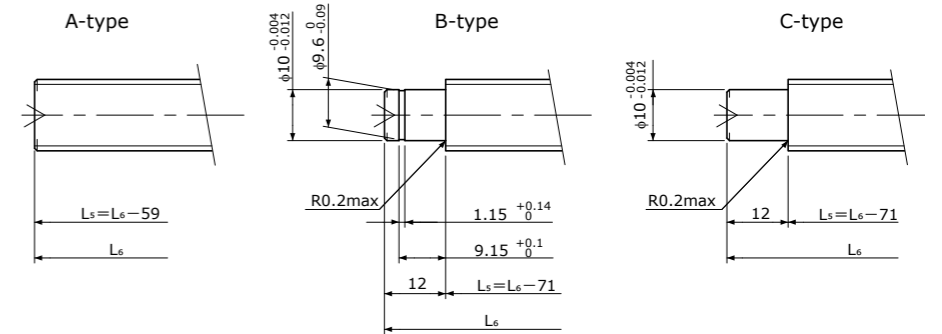

L5: Thread length after end-journal machining. 追加加工后的螺纹部长度
L6: Total length after end-journal machining. 追加加工后的总长

Support-unit Recommendation 推荐的支架组件	
Supported-side 支撑侧	—
Fixed-side 固定侧	—

D-type: Other than the above. 上述以外的形状

Unit(单位):mm

Ball Screw Model 滚珠丝杠型号	Travel 行程	Grade 精度	Shaft length 丝杠轴长度				Lead accuracy 导程精度		Total Run-out 全跳动	Axial play 轴向间隙	Preload Torque 预压扭矩 Nm	Basic Load Rating 基本额定负载 N	
			L1	L2	L3	L4	Travel deviation 代表移动量误差 e _p	Variation 波动 V _u				Dynamic 额定动负载 Ca	Static 额定静负载 Coa
SG1402-141R200C3	115	C3	141	145	155	200	±0.010	0.008	0.025	0 Spacer Ball 间隔钢珠 (1:1)	0.010~ 0.050	2000	3800
SG1402-191R250C3	165	C3	191	195	205	250	±0.010	0.008	0.030				
SG1402-241R300C3	215	C3	241	245	255	300	±0.012	0.008	0.030				
SG1402-291R350C3	265	C3	291	295	305	350	±0.012	0.008	0.040				
SG1402-391R450C3	365	C3	391	395	405	450	±0.013	0.010	0.050				
SG1402-141R200C5	115	C5	141	145	155	200	±0.020	0.018	0.040	~0.005	—	3200	7500
SG1402-191R250C5	165	C5	191	195	205	250	±0.020	0.018	0.045				
SG1402-241R300C5	215	C5	241	245	255	300	±0.023	0.018	0.045				
SG1402-291R350C5	265	C5	291	295	305	350	±0.023	0.018	0.055				
SG1402-391R450C5	365	C5	391	395	405	450	±0.025	0.020	0.060				

Note) Please refer to page A206 for order code of end-journal machining. 注) 追加加工的公称型号指定方式请参照A206页。

SG1404 | Shaft dia.(轴径) $\phi 14$ Lead(导程)4mm | C3&C5

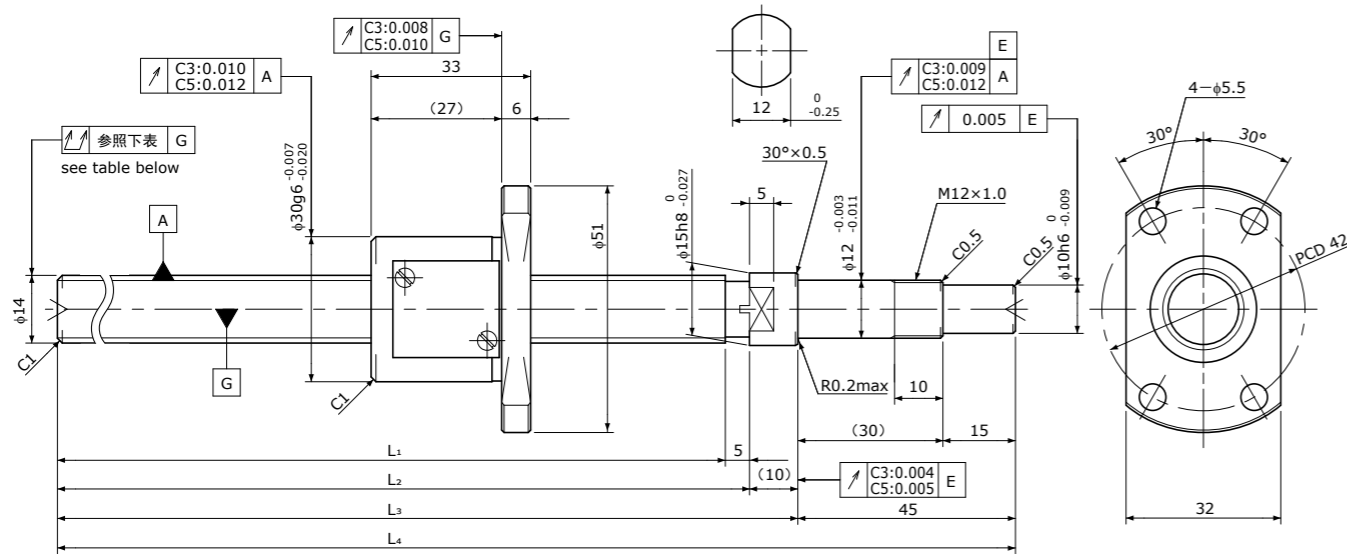

Unit(单位):mm

Ball Screw Specifications 主要技术参数	
Ball size 钢珠直径	$\phi 2.381$
Number of thread 螺纹条数	1
Thread direction 螺纹旋向	Right 右旋
Shaft root dia. 丝杠轴底径	$\phi 11.8$
Number of circuit 循环数	3.7×1
Shaft, Nut material 轴、螺母材质	SCM415H
Surface hardness 螺纹部表面硬度	HRC58~62 (Thread area)
Anti-rust treatment 防锈处理	Anti-rust oil 防锈油

Supported-side end-journal profile 支撑侧轴端加工形状

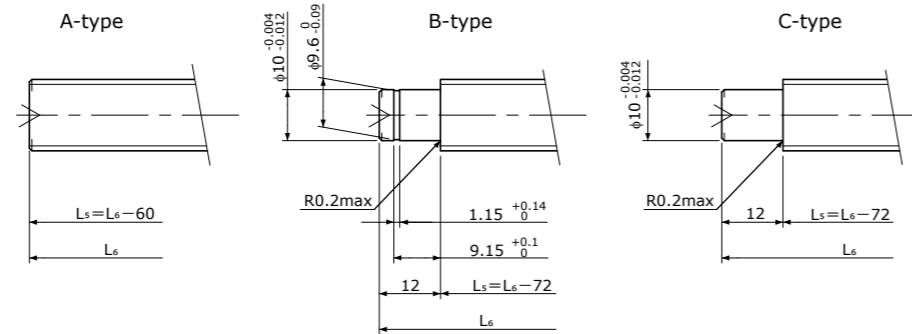

L₅: Thread length after end-journal machining. 追加加工后的螺纹部长度
L₆: Total length after end-journal machining. 追加加工后的总长

Support-unit Recommendation 推荐的支架组件	Supported-side 支撑侧	Fixed-side 固定侧
	—	—

D-type: Other than the above. 上述以外的形状 Unit(单位):mm

Ball Screw Model 滚珠丝杠型号	Travel 行程	Grade 精度	Shaft length 丝杠轴长度				Lead accuracy 导程精度		Total Run-out 全跳动	Axial play 轴向间隙	Preload Torque 预压扭矩 Nm	Basic Load Rating 基本额定负载 N	
			L ₁	L ₂	L ₃	L ₄	Travel deviation 代表移动量误差 e _p	Variation 波动 V _u				Dynamic 额定动负载 Ca	Static 额定静负载 Coa
SG1404-190R250C3	155	C3	190	195	205	250	± 0.010	0.008	0.030	0 Spacer Ball 间隔钢珠 (1:1)	0.020~ 0.070	3600	5800
SG1404-240R300C3	205	C3	240	245	255	300	± 0.012	0.008	0.030				
SG1404-290R350C3	255	C3	290	295	305	350	± 0.012	0.008	0.040				
SG1404-390R450C3	355	C3	390	395	405	450	± 0.013	0.010	0.050				
SG1404-490R550C3	455	C3	490	495	505	550	± 0.015	0.010	0.055				
SG1404-190R250C5	155	C5	190	195	205	250	± 0.020	0.018	0.045	~0.005	—	5700	11600
SG1404-240R300C5	205	C5	240	245	255	300	± 0.023	0.018	0.045				
SG1404-290R350C5	255	C5	290	295	305	350	± 0.023	0.018	0.055				
SG1404-390R450C5	355	C5	390	395	405	450	± 0.025	0.020	0.060				
SG1404-490R550C5	455	C5	490	495	505	550	± 0.027	0.020	0.075				

Note)Please refer to page A206 for order code of end-journal machining. 注)追加加工的公称型号指定方式请参照A206页。

SG1505 | Shaft dia.(轴径) $\phi 15$ Lead(导程)5mm | C5

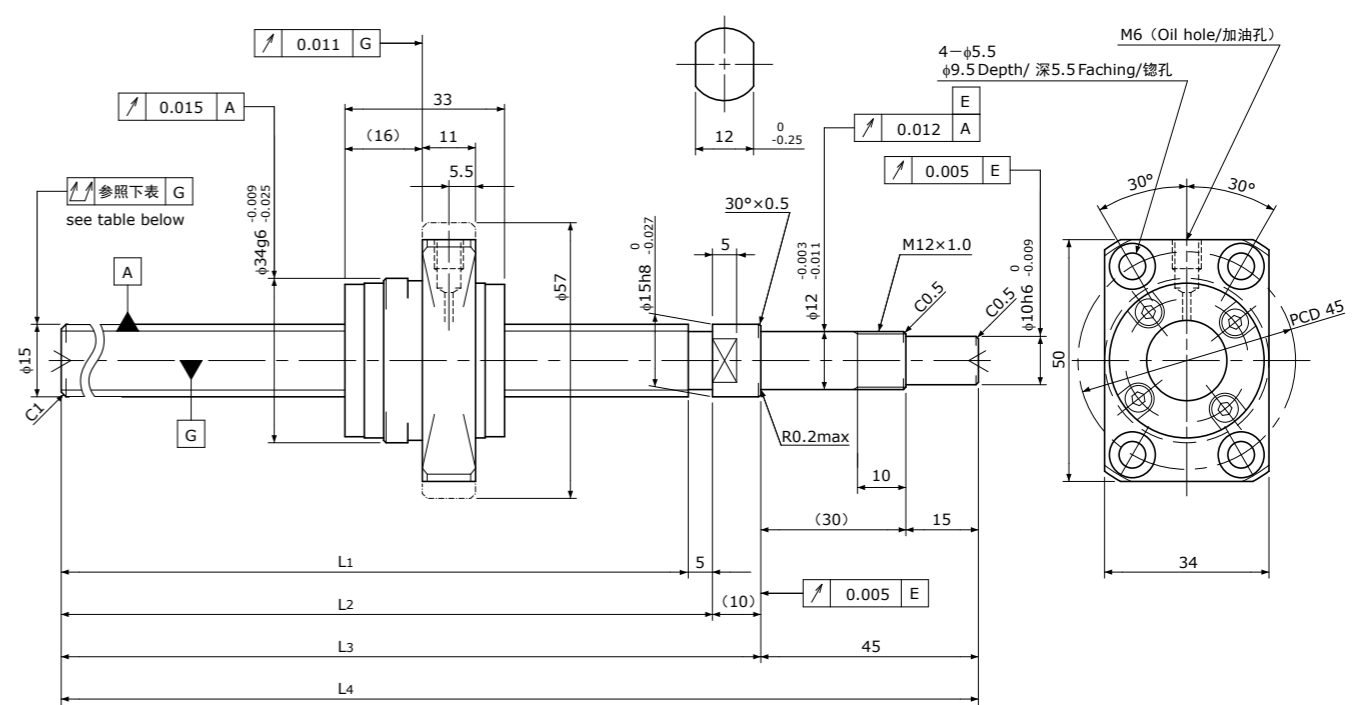

Unit(单位):mm

Ball Screw Specifications 主要技术参数	
Ball size 钢珠直径	$\phi 3.175$
Number of thread 螺纹条数	1
Thread direction 螺纹旋向	Right 右旋
Shaft root dia. 丝杠轴底径	$\phi 12.2$
Number of circuit 循环数	3.7×1
Shaft, Nut material 轴、螺母材质	SCM415H
Surface hardness 螺纹部表面硬度	HRC58~62 (Thread area)
Anti-rust treatment 防锈处理	Anti-rust oil 防锈油

Supported-side end-journal profile 支撑侧轴端加工形状

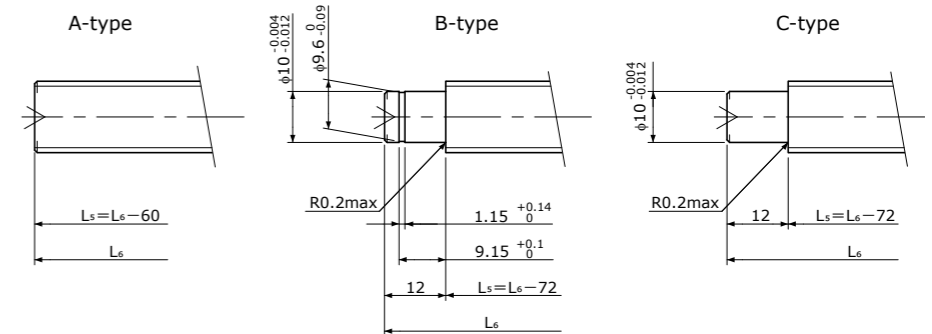

L₅: Thread length after end-journal machining. 追加加工后的螺纹部长度
L₆: Total length after end-journal machining. 追加加工后的总长

Support-unit Recommendation 推荐的支架组件	Supported-side 支撑侧	Fixed-side 固定侧
	—	—

D-type: Other than the above. 上述以外的形状 Unit(单位):mm

Ball Screw Model 滚珠丝杠型号	Travel 行程	Grade 精度	Shaft length 丝杠轴长度				Lead accuracy 导程精度		Total Run-out 全跳动	Axial play 轴向间隙	Preload Torque 预压扭矩 Nm	Basic Load Rating 基本额定负载 N	
			L ₁	L ₂	L ₃	L ₄	Travel deviation 代表移动量误差 e _p	Variation 波动 V _u				Dynamic 额定动负载 Ca	Static 额定静负载 Coa
SG1505-340R400C5	305	C5	340	345	355	400	± 0.025	0.020	0.055	~0.005	—	8900	17000
SG1505-540R600C5	505	C5	540	545	555	600	± 0.030	0.023	0.075				

Note)Please refer to page A206 for order code of end-journal machining. 注)追加加工的公称型号指定方式请参照A206页。

Standard products in stock SG series
标准库存品 SG系列

SG1510

Shaft dia.(轴径)φ15 Lead(导程)10mm

C5

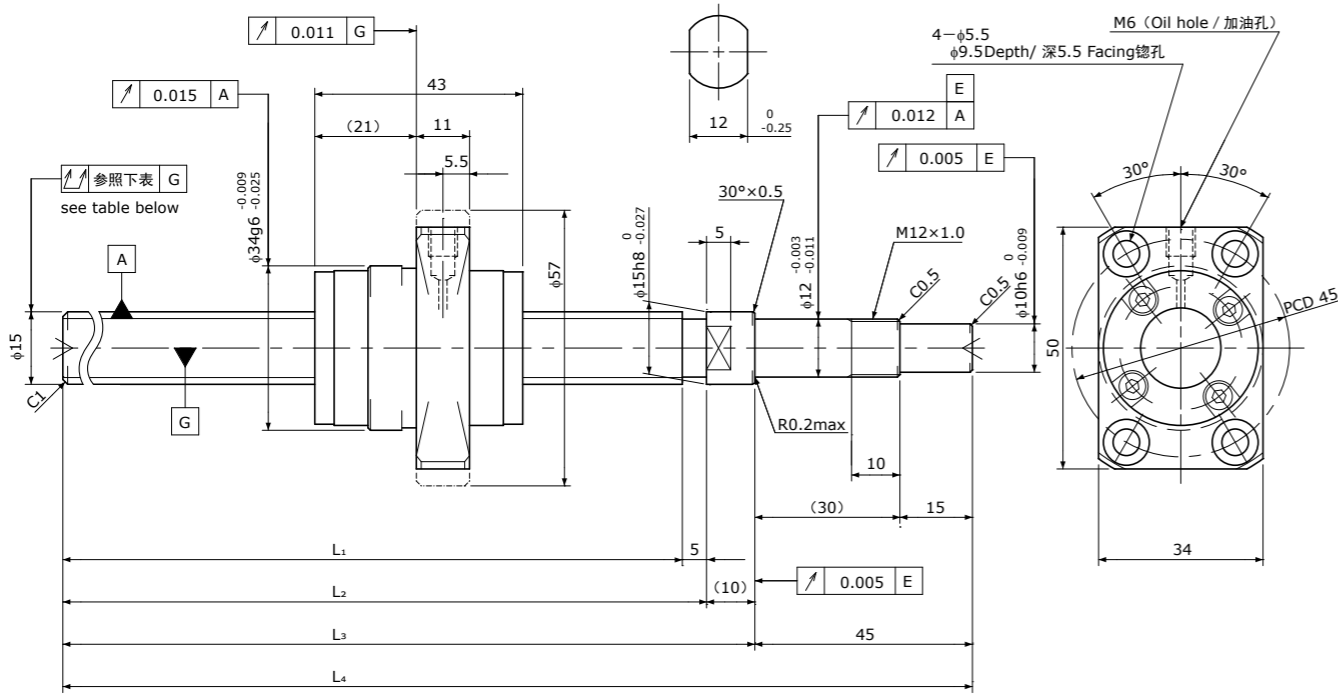

Unit(单位):mm

Ball Screw Specifications 主要技术参数	
Ball size 钢珠直径	φ3.175
Number of thread 螺纹条数	2
Thread direction 螺纹旋向	Right 右旋
Shaft root dia. 丝杠轴底径	φ12.2
Number of circuit 循环数	2.7×2
Shaft, Nut material 轴、螺母材质	SCM415H
Surface hardness 螺纹部表面硬度	HRC58~62 (Thread area)
Anti-rust treatment 防锈处理	Anti-rust oil 防锈油

Supported-side end-journal profile 支撑侧轴端加工形状		
A-type	B-type	C-type
$L_s = L_6 - 60$	$L_s = L_6 - 72$	$L_s = L_6 - 72$
<p>L_s: Thread length after end-journal machining. 追加加工后的螺纹部长度 L_6: Total length after end-journal machining. 追加加工后的总长</p>		
<p>Support-unit Recommendation 推荐的支架组件</p> <p>Supported-side 支撑侧 : — Fixed-side 固定侧 : —</p>		
D-type : Other than the above. 上述以外的形状		

Unit(单位):mm

Ball Screw Model 滚珠丝杠型号	Travel 行程	Grade 精度	Shaft length 丝杠轴长度				Lead accuracy 导程精度		Total Run-out 全跳动	Axial play 轴向间隙	Preload Torque 预压扭矩 Nm	Basic Load Rating 基本额定负载 N	
			L ₁	L ₂	L ₃	L ₄	Travel deviation 代表移动量误差 e _p	Variation 波动 V _u				Dynamic 额定动负载 Ca	Static 额定静负载 Coa
SG1510-340R400C5	295	C5	340	345	355	400	±0.025	0.020	0.055	~0.005	—	12000	25000
SG1510-540R600C5	495	C5	540	545	555	600	±0.030	0.023	0.075				

Note)Please refer to page A206 for order code of end-journal machining. 注)追加加工的公称型号指定方式请参照A206页。

Standard products in stock SG series
标准库存品 SG系列

SG1520

Shaft dia.(轴径)φ15 Lead(导程)20mm

C5

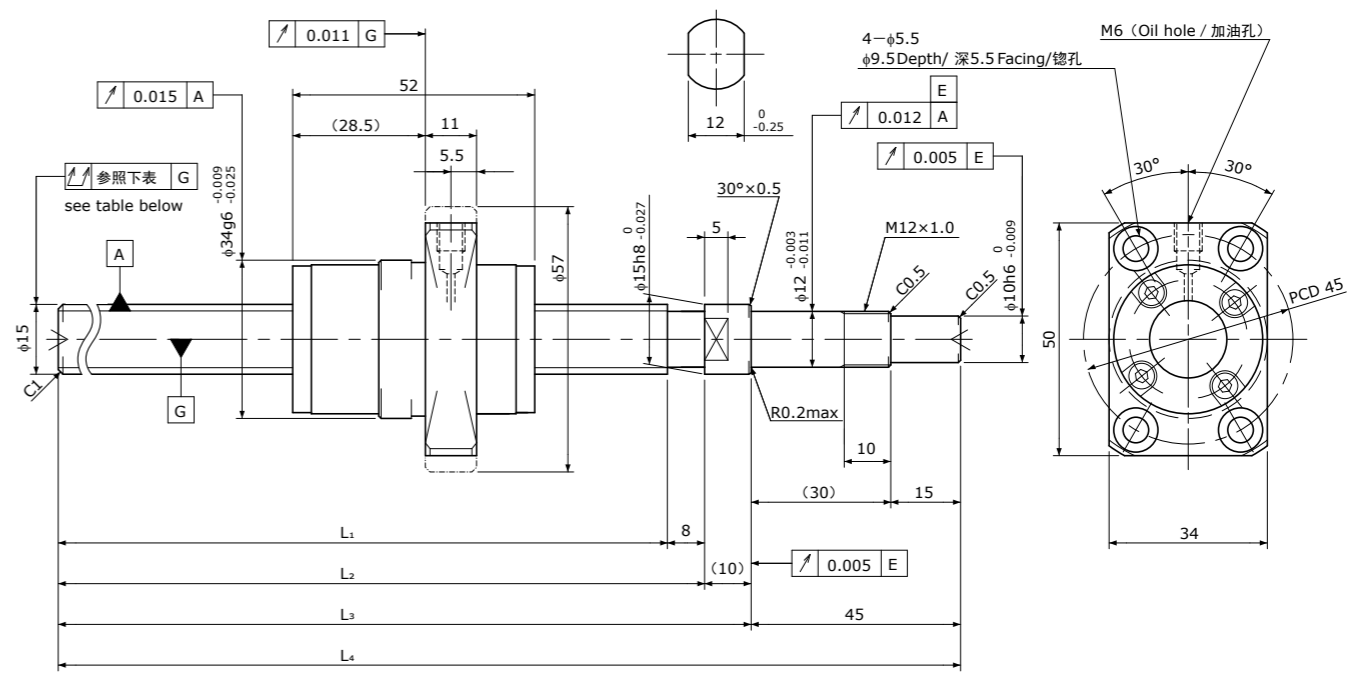

Unit(单位):mm

Ball Screw Specifications 主要技术参数	
Ball size 钢珠直径	φ3.175
Number of thread 螺纹条数	2
Thread direction 螺纹旋向	Right 右旋
Shaft root dia. 丝杠轴底径	φ12.4
Number of circuit 循环数	1.7×2
Shaft, Nut material 轴、螺母材质	SCM415H
Surface hardness 螺纹部表面硬度	HRC58~62 (Thread area)
Anti-rust treatment 防锈处理	Anti-rust oil 防锈油

Supported-side end-journal profile 支撑侧轴端加工形状		
A-type	B-type	C-type
$L_s = L_6 - 63$	$L_s = L_6 - 75$	$L_s = L_6 - 75$
<p>L_s: Thread length after end-journal machining. 追加加工后的螺纹部长度 L_6: Total length after end-journal machining. 追加加工后的总长</p>		
<p>Support-unit Recommendation 推荐的支架组件</p> <p>Supported-side 支撑侧 : — Fixed-side 固定侧 : —</p>		
D-type : Other than the above. 上述以外的形状		

Unit(单位):mm

Ball Screw Model 滚珠丝杠型号	Travel 行程	Grade 精度	Shaft length 丝杠轴长度				Lead accuracy 导程精度		Total Run-out 全跳动	Axial play 轴向间隙	Preload Torque 预压扭矩 Nm	Basic Load Rating 基本额定负载 N	
			L ₁	L ₂	L ₃	L ₄	Travel deviation 代表移动量误差 e _p	Variation 波动 V _u				Dynamic 额定动负载 Ca	Static 额定静负载 Coa
SG1520-337R400C5	285	C5	337	345	355	400	±0.025	0.020	0.055	~0.005	—	8000	16000
SG1520-537R600C5	485	C5	537	545	555	600	±0.030	0.023	0.075				

Note)Please refer to page A206 for order code of end-journal machining. 注)追加加工的公称型号指定方式请参照A206页。